

K.W. COMMUNICATIONS SINGLE-SIDEBAND TRANSCEIVER

# **KW 2000 E**

# **INSTRUCTION**

# **MANUAL**

**ISSUE 1**

**DANGER**

EXTREME CARE MUST BE TAKEN  
WHEN SERVICING THIS EQUIPMENT,  
ESPECIALLY IF ANY COVERS ARE  
REMOVED, SINCE POTENTIALS AS  
HIGH AS 900 VOLTS ARE PRESENT.

K.W. COMMUNICATIONS LTD.,  
VANGUARD WORKS, 1 HEATH STREET, DARTFORD, KENT. DA1 2LH.  
Tel: DARTFORD 25574 and 21919

H F Communications Equipment.

KW 2000 Transceiver

Serial No

E 377

E 377

W/O No

6023

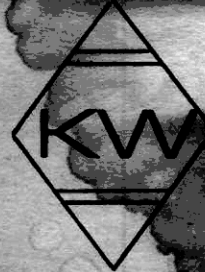

KW Communications Ltd.

Dartford. Kent. England.

POWER SUPPLY SER. NO EP 339

## CONTENTS

### SECTION 1

#### GENERAL DESCRIPTION AND SPECIFICATION

	<u>PAGE</u>
1.1 Introduction	1 - 1
1.2 Receiver	1 - 1
1.3 Transmitter	1 - 1
1.4 Power Supplies	1 - 1
1.5 Antenna	1 - 1
1.6 Specification	1 - 2, 3
1.7 Valve and Semi-Conductor	1 - 3

### SECTION 2

#### CIRCUIT DESCRIPTION

2.1 Transmitter Circuits	2 - 1
2.2 Receiver Circuits	2 - 2
2.3 Oscillators	2 - 2, 3
2.4 Power Supplies	2 - 3, 4

### SECTION 3

#### INSTALLATION

3.1 Unpacking	3 - 1
3.2 Fixed Station Installation	3 - 1
3.3 Installation with KW1000	3 - 1
3.4 Mobile Installation	3 - 1
3.5 Mobile Antenna Installation	3 - 1, 2
3.6 Noise Suppression	3 - 2
3.7 Initial Checks	3 - 2

### SECTION 4

#### OPERATION

4.1 Receiver	4 - 1, 2
4.2 Transmitter	4 - 2, 3
4.3 Setting of PA Load Control	4 - 3
4.4 WWV	4 - 3

## SECTION 5

### SERVICE INSTRUCTION

### PAGE

5.1	General	5 - 1
5.2	Trouble Analysis	5 - 1, 2
5.3	Signal Tracing Procedures	5 - 2
5.4	Voltage and Resistance Measurements	5 - 2
5.5	Alignment Procedure	5 - 3, 4
5.6	Pre-selector 3.5 MHz Band	5 - 4
5.7	V.I.F. Transformers and 455 KHz IF	5 - 4, 5
5.8	S Meter Calibration	5 - 5
5.9	Carrier Balance	5 - 5
5.10	Transmitter Sensitivity	5 - 5, 6
5.11	VFO Calibration and IRT	5 - 6
5.12	Pre-selector 29.5 MHz Band	5 - 6
5.13	Neutralising 29.5 MHz Band	5 - 6, 7
5.14	Pre-selector 29.0 MHz Band	5 - 7
5.15	Pre-selector 28.5 MHz Band	5 - 7
5.16	Pre-selector 28.0 MHz Band	5 - 7
5.17	Pre-selector 21.0 MHz Band	5 - 7
5.18	Pre-selector 15.0 MHz Band	5 - 7
5.19	Pre-selector 11.0 MHz Band	5 - 8
5.20	Pre-selector 7.0 MHz Band	5 - 8
5.21	Pre-selector 1.8 MHz Band	5 - 8
5.22	Alignment of 100 KHz Calibrator	5 - 8

## SECTION 6

### TABLES

6.1	Signal Levels Receiver	6 - 1
6.2	Signal Levels Transmitter	6 - 2
6.3	Voltage Measurements Receive	6 - 3, 4
6.4	Voltage Measurements Transmit	6 - 5, 6
6.5	Resistance Measurements	6 - 7

## SECTION 7

### ILLUSTRATIONS

7.1	Location of Valves and Crystals	7 - 1
7.2	Location of Adjustments	7 - 2
7.3	Interconnections Fixed Station	7 - 3

SECTION 7 (Cont'd.)

ILLUSTRATIONS (Cont'd.)

	<u>PAGE</u>
7.4 Interconnections Mobile Station	7 - 4
7.5 Interconnections with KW1000	7 - 5
7.6 Block Diagram	7 - 6
Transceiver Circuit Diagram	
AC Power Supply Circuit Diagram	
VOX Circuit Diagram	

GUARANTEE

## K.W. 2000E SSB TRANSCEIVER

### SECTION 1

#### GENERAL DESCRIPTION AND SPECIFICATION

##### 1.1 Introduction

The KW2000E TRANSCEIVER is a complete unit enabling transmission and reception of single-sideband and CW on all amateur bands between 1.8 MHz and 30 MHz. Reception of AM signals is also possible. It is capable of transmitting and receiving either upper or lower sideband signals. Separate power units for operation on 105-240v AC and 12v DC make the equipment suitable for "fixed" or "mobile" stations where a compact installation is required.

##### 1.2 Receiver

The Receiver section of the KW2000E transceiver is a double conversion superhet with a CRYSTAL CONTROLLED 1st MIXER, and a highly stable VFO, a MECHANICAL FILTER for optimum performance on SSB, and a CRYSTAL CONTROLLED CARRIER OSCILLATOR. Independent receiver frequency tuning (IRT) is provided with a deviation of approximately  $\pm 6$  KHz. A product detector is used for all modes of reception. Output stage is capable of delivering 1.0 watts of audio to the loudspeaker. The equipment is fitted with a crystal calibrator 100 KHz marker.

##### 1.3 Transmitter

The exciter/transmitter section uses the same CARRIER OSCILLATOR, MECHANICAL FILTER, VFO and HF XTAL OSCILLATOR as the receiving section. The PA stage has an output of 100 watts P.E.P. on SSB and 150 watts D.C. input on CW. A Pi output stage provides a variable output impedance. Independent transmitter frequency tuning (ITT) is provided with a deviation of approximately  $\pm 6$  KHz from the indicated dial reading. The equipment is fitted with Voice Control but can also be operated with a "press to talk" function.

##### 1.4 Power Supplies

Two power supplies are available, one for operation on 105-120 or 210-240v  $\pm 5\%$  45-65 Hz AC mains supply, and the other for operation on 12 volts DC battery supply. A power reduction switch is fitted to both types of power supply unit for 160 metre operation. The AC power supply has a loudspeaker incorporated within the cabinet.

##### 1.5 Antenna

The antenna should have a VSWR of 2:1 or better. With some multi-band antennas it may be advisable to use an antenna matching unit such as the KW E-Z MATCH or KW107.

1.6 Specification KW2000E

Frequency range . . . . .	1.8 - 2.0, 3.5 - 4.0, 7.0 - 7.5, 14.0 - 14.5, 21.0 - 21.5, 28.0 - 30.0 MHz Plus on receive only 2.0 - 2.3, 15.0 - 15.5 MHz.
Mode . . . . .	Single sideband (either sideband selectable) or CW.
Type of service . . . . .	SSB-continuous; CW-50% duty cycle.
Power requirements . . . . .	Fixed Station 105 - 120 or 210 - 240v AC 45 - 65 Hz.  Mobile Station 12.6 volts DC Nominal. 8 - 25 amps.
Power input to PA . . . . .	180 watts PEP on SSB, 150 watts on CW.
Power output . . . . .	100 watts PEP (nominal) into 52 ohms.
Audio input . . . . .	High impedance microphone.
RF output impedance . . . . .	52 ohms with not more than 2.0-to-1 swr.
RF input impedance . . . . .	52 ohms.
Matching speaker impedance . . . . .	3 - 4 ohms.
Calibrator . . . . .	100 KHz crystal oscillator.
Frequency stability . . . . .	Within 100 Hz following 30 minute warm-up. Not more than 100 Hz with $\pm 10\%$ line voltage variation.
Calibration accuracy . . . . .	2 KHz after midband calibration.
Backlash . . . . .	Not more than 50 Hz.
Keying . . . . .	Break-in CW with sidetone provided.
Audio frequency response . . . . .	300 to 2600 Hz $\pm 6$ db.
Carrier suppression . . . . .	Carrier 50 db down from Peak Output.
Unwanted sideband . . . . .	45 db down from Peak Output.
Oscillator feedthrough and/or mixer products (undesired) . . . . .	50db down from output signal. (40db down at 3500 KHz).
Second harmonic radiation . . . . .	40 db down from output signal.
Third order distortion . . . . .	27 db down from output signal.
Noise level . . . . .	40 db below single tone.
Receiver sensitivity . . . . .	0.5 microvolt for 10db signal-plus-noise to noise ratio in amateur bands.
Receiver selectivity . . . . .	2.4 KHz bandwidth at 6db down, 5 KHz bandwidth at 60db down.
Receiver spurious responses . . . . .	Image rejection better than 50db. Internal spurious signals below one microvolt equivalent antenna input, in amateur bands.

Automatic gain control . . . . . Audio output level does not change more than 6db as the input signal is changed from 1 microvolt to 10 mv.  
Fast attack and slow release AGC action on voice and CW.

IRT/ITT/IRTT . . . . .  $\pm 6$  KHz.

Receiver output level . . . . . 1.0 watt.

Dimensions in cabinet . . . . .

Transceiver . . . . . Height 15.8cm Width 32.2cm Depth 33.7cm  
(6 $\frac{1}{4}$ " ) (13 $\frac{7}{8}$ " ) (13 $\frac{1}{4}$ " )

AC Power Supply . . . . . Height 15.8cm Width 18.7cm Depth 33cm  
(6 $\frac{1}{4}$ " ) (7 $\frac{3}{8}$ " ) (13" )

12v DC Power Unit . . . . . Height 13.3cm Width 11.1cm Depth 20.3cm  
(5 $\frac{1}{4}$ " ) (4 $\frac{3}{8}$ " ) (8" )

Weight . . . . .

Transceiver . . . . . 7 kg (15 $\frac{1}{2}$ lb)

AC Power Unit . . . . . 8.7kg (19 lb)

12v DC Power Unit . . . . . 3.5kg ( 6 $\frac{1}{2}$ lb)

1.7 Valve and Semi-Conductor Compliment

<u>SYMBOL</u>	<u>TYPE</u>	<u>FUNCTION</u>	<u>SYMBOL</u>	<u>TYPE</u>	<u>FUNCTION</u>
V1	ECC83 12AX7	Mic Amp/Tone Osc	V10	EF91 6AM6	H.F. Osc.
V2	ECC81 12AT7	Car Osc Cath Follower	V11	ECL82 6BM8	A.F. Output
V3	EF183 6EH7	Tx I.F. Amp	V12	ECC83 12AX7	Prod Det
V4	ECC81 12AT7	1st Tx Mixer	V13	EF93 6BA6	2nd Rx IF Amp
V5	ECC81 12AT7	2nd Tx Mixer	V14	EF93 6BA6	1st Rx IF Amp
V6	EL821 6CH6	Driver	V15	EK90 6BE6	2nd Rx Mixer
V7	QV06/20 6146	P.A.	V16	ECC85 6AQ8	1st Rx Mixer
V8	QV06/20 6146	P.A.	V17	12BZ6	Rx RF Amp
V9	EB91 6AL5	AGC Det	V18	EF93 6BA6	100 KHz Cal
			V19	ECF82 6U8	VFO.
D1, 2	Balanced Modulator	AA119	D3	IRT Vari-cap	8SC20
D4	Rx Bias Blocking Rect	BY236	D5	CW Blocking Rect	BY236
D6, 7	AIC Rectifiers	BY236	D8	Tx Bias Blocking Rect	BY236
D9	Cal Set Diode	1N4148	D10	Stab HT Regulator	ZX150
D11	Vox -10v Stabiliser	IZM10	D12,13	Vox -12v Stabilisers	ZF6.2
	LPI, 2	Dial Lamps		6.3v	0.15A

Power Supply Semi-conductors

D1-4	EHT Rectifiers	BY238	D5-8	HT Rectifiers	BY238
D9	Bias Rectifier	BY238	IC1	Voltage Stabiliser	IM309K
D11,12	IC1 Compensating Diodes	BYX36-150	D10	Positive DC Rect	3A05

F1 Mains Ruse 3 amp (240v) 5 amp (115v)

## SECTION 2

### CIRCUIT DESCRIPTION

#### 2.1. Transmitter Circuits

##### 1. A.F. Stages

Microphone input is connected to the grid of the MIC AMP V1a amplified and coupled to the grid of the CATHODE FOLLOWER V2 across MIC GAIN control. Output from the cathode follower is fed to the resistive balance point of the BALANCED MODULATOR. In the TUNE position (this is USB) or when the key is pressed, output from the TONE OSCILLATOR (V1b) at 1500 Hz is fed to the grid of the CATHODE FOLLOWER (V2).

##### 2. AIC Circuit

Detected Audio from the Power Amplifier Grid circuit is rectified by D6 and D7, the negative DC output is fed to the grid of the 455 KHz Amplifier V3. A fast-attack slow release time constant is used to prevent overdriving on initial syllables and to hold gain constant between words. Diode D8 is used to prevent the transmitter muting bias charging the AIC circuit when on receive.

##### 3. VOX Circuits

When VOX is selected on the CONTROL SWITCH audio is taken from the anode of V1a (either tone or speech) and fed to the wiper of the VOX GAIN potentiometer. The signal is amplified by TR1, TR2 and fed to the base of TR4. This transistor is DC coupled to TR5 in such a manner that when audio is applied to its base TR5 is forward biased into conduction and the VOX RELAY energised, switching the transmitter section on and muting the receiver. The length of time the VOX RELAY remains energised after audio is removed is dependent on the time constant formed by C7 and the VOX DELAY potentiometer.

##### 4. Anti-Trip

Audio is taken from the receiver output valve and applied to the base of TR3 via the ANTI TRIP potentiometer. The voltage developed across the emitter resistor of TR3 is fed on to the base of TR4 thus altering its threshold voltage. The ANTI TRIP circuit prevents the loudspeaker output (picked up by the microphone) tripping the VOX circuits.

##### 5. Balanced Modulator and Low Frequency IF Circuits

Audio output from the cathode of V2a and the CARRIER OSCILLATOR voltage are fed to the slider of the CARRIER BALANCE potentiometer RV2. Both upper and lower sideband output from the BALANCED MODULATOR are coupled through IF transformer IFT1 to the grid of the IF AMPLIFIER V3. Output from the IF AMPLIFIER is fed to the MECHANICAL FILTER. The Passband of the FILTER is centred at a nominal frequency of 455 KHz. This passes either upper or lower sideband, depending upon which sideband is selected at the FUNCTION switch. This operates either CARRIER OSC crystal X1 or X2. The SSB output of the FILTER is fed to the control grid of the transmitter first mixer.

##### 6. Balanced Mixers

The 455 KHz signal is fed to the control grid of the FIRST BALANCED MIXER V4 and the VFO output 2200 KHz to 2700 KHz is fed to the signal input cathode and to the grid of the second half of the twin triode. This arrangement cancels the high frequency injection signal within the mixer and converts the 455 KHz signal to a 2.655 to 3.155 MHz variable I.F. signal. The coupling networks between the anodes of the FIRST MIXER and the SECOND BALANCED MIXER consists of two transformers tuned by a twin gang capacitor which is coupled to the VFO

## 6. Balanced Mixers (Cont'd)

capacitor. The V.I.F. signal is fed to the control grid of the SECOND BALANCED MIXER V5, and the H.F. injection signal voltage CRYSTAL OSCILLATOR V10 is fed to the signal input cathode and to the control grid of the second half of the twin triode. The H.F. injection voltage is cancelled within the mixer and the V.I.F. signal is converted to the desired frequency of operation.

## 7. RF Circuits

The tuned circuits associated with the anodes of V5, V17 grid and the anode of V6 are ganged to the PRE-SELECTOR tuning control. The signal from the second BALANCED MIXER is amplified by the DRIVER (V6) to drive the POWER AMPLIFIERS (V7, 8) in CLASS AB1. Output from the PA is tuned by a PI NETWORK and fed to the ANTENNA through contacts of transmit-receive relay R12.

## 2.2 Receiver Circuits

### 1. RF Circuits

Signal input from the ANTENNA is connected through relay contacts to the tuned input circuit L22-28. The signal voltage is then applied to the grid of the RF AMPLIFIER V17. The tuned circuits L8-14 couple the amplified signal to the grid of the FIRST RECEIVER MIXER V16.

### 2. Receiver Mixers

The amplified RF SIGNAL is fed to the signal grid of the RECEIVER FIRST MIXER V16 and the H.F. OSCILLATOR injection signal is fed to the control grid. The anode load of V16 is V.I.F. transformers, IFT2, IFT3, which are tuned to a frequency which is the difference between the input signal and the H.F. oscillator, this is 2655 KHz to 3155 KHz. Output of IFT3 is applied to the signal grid of the RECEIVER SECOND MIXER V15. The VFO (V19) output is injected to the control grid of V15, producing an output frequency of 455 KHz at the anode which is fed to the MECHANICAL FILTER.

### 3. IF Circuits

The output from the MECHANICAL FILTER at 455 KHz is applied to the grid of the first IF AMP (V14). The IF signal is amplified by V14 and V13 and applied through IFT5 to the AGC DETECTOR V9 and the grid of the PRODUCT DETECTOR V12. The CARRIER OSCILLATOR (V2b) is also used as a BFO, the output of which is fed to the cathode of V12. The resultant mixing process produces the detected signal at audio frequencies. Output of the AGC detector is used to control the 2nd IF amplifier and the RF amplifier. The AGC is fast attack, slow release, for SSB and CW operation. The AGC threshold is 1.5 microvolt with 25 microvolts necessary to read S9 on the 'S' meter.

### 4. AF Circuits

Output from the product detector is applied through the A.F. GAIN control RV4, to the grid of the AF AMP V14. Amplified audio output is coupled to the grid of the AF OUTPUT AMP V11b, which produces the power to operate the loudspeaker or headphones. Low Impedance headphones are recommended for use with KW2000E.

## 2.3 Oscillators

### 1. Tone Oscillators

The TONE OSCILLATOR V1b operates when the FUNCTION switch is at TUNE or when the key is pressed with the FUNCTION switch at CW. A phase

## 2.3 Oscillators

### 1. Tone Oscillators (Cont'd)

shift oscillator circuit is employed operating at approximately 1500 Hz. The output is fed to the transmitter audio CATHODE FOLLOWER V2a for TUNE and CW, and across the RECEIVER AF GAIN control for SIDE TONE monitoring of CW Transmission.

### 2. Carrier Oscillator

The CARRIER OSCILLATOR is crystal controlled at a frequency which puts the carrier approximately 20db down the skirt of the MECHANICAL FILTER X1 LOWER or X2 UPPER SIDEBAND crystals are selected by the FUNCTION switch.

### 3. Variable Frequency Oscillator

The VFO operates in the range 2200 to 2700 KHz. In addition to switching the UPPER or LOWER SIDEBAND crystal, the VFO must be moved in frequency, by an amount equal to the spacing of the carrier crystals. The VFO is moved by this amount when switching to LSB, and is accomplished by switching a one turn coil in circuit by operation of a reed relay RL3.

### 4. High-Frequency Crystal Oscillator

The H.F. CRYSTAL OSCILLATOR V10, is crystal controlled by one of 10 crystals selected by BAND SWITCH. The output frequency of this oscillator is always 3155 KHz higher than the lower edge of the desired band.

### 5. Crystal Calibrator

The 100 KHz CRYSTAL CALIBRATOR signal is fed to The receive contact of RL2, which is connected to the RF AMPLIFIER tuned input circuits. The 100 KHz signal may be calibrated to an external standard by adjusting C158, which is located next to the 100 KHz crystal.

## 2.4 Power Supplies

### 1. AC Power Supply

The AC POWER SUPPLY operates from 105-120 or 210-240v AC  $\pm 5\%$  45-65 Hz. The AC circuit is looped through the inter-connecting cable to the FUNCTION switch on the transceiver, in order that the power supply can be switched on and off from the operating position. Transformer FM2842 has four secondary windings which supply the EHT voltage, the HT voltage, the negative bias, the 12 volt heater + 12 volts for the relays and + 6.3v for the VFO/HF OSC heaters. The AC line is fused in the LIVE side of the mains with F1.

#### 1a EHT 300 Volts

The transformer first secondary winding is tapped for reduced power operation, a switch is provided on the rear of the power supply for this purpose. Voltage from the secondary one is applied to a full wave bridge rectifier circuit, using four silicon rectifiers D1-D4. The resulting DC is approximately +800 volts with the HIGH LOW power switch at HIGH and 680 volts with it at LOW. This voltage is applied to the anodes of the PA V7, 8.

#### 1b HT + 250 volts

Secondary two feeds a bridge rectifier circuit using four silicon rectifiers D5-D8, which delivers + 250 volts DC via the smoothing circuits.

1c Negative Bias

Two negative bias voltages are required and are provided by rectifying secondary three with D9. This bias voltage is smoothed and provides the -85v for the receiver and transmitter muting, a potential divider is used to give -55 to -85 adjustable to RV1 located on the rear of the PSU, for the operating bias of the PA.

1d Heaters and Positive 12 Volts

The remaining winding is for the 12v AC heater line, this supply is also rectified by D10 to provide the +12v DC necessary to operate the relays 6.3 volts DC is provided via IC1 to operate the heaters of V19, V10.

1e Loudspeaker

The loudspeaker is built into the AC power supply cabinet.

2. DC Power Supply

This Unit is intended to be used from a 12 volt storage battery such as is normally fitted in a vehicle. The input voltage should not be allowed to drop below 11.5 volts, otherwise frequency modulation may be noticeable on the transmitted signal.

2a The Power supply consists of a two transformer DC to DC converter employing toroidal windings for optimum performance, and gives a conversion efficiency of 85%. A small driver transformer operating at 600 Hz controls the switching of the two power transistors. The circuit includes a silicon diode to ensure reliable starting under all load conditions and over a wide temperature range.

2b The square wave produced by the switched transistors is stepped up via a linear transformer to the required output voltages. The 750v and 245v DC supplies are obtained from Silicon Rectifiers in a bridge circuit followed by smoothing. The low current bias supplies are derived from a half wave circuit. A High/Low power switch enables the 750 volts to be reduced to 675v. Both input and output circuits are filtered to minimise interference.

2c The power supply can be supplied for mobile installations having an earth on either positive or negative battery terminals. A remote switching relay is included to eliminate long high current leads to control position whilst a protection circuit prevents damage to the power supply should the input polarity be accidentally reversed.

2d A 6 volt stabilised line is provided for the heaters of V10, V19 to reduce VFO drift with varying battery voltages. The line is stabilised by a Zener Diode.

## SECTION 3

### INSTALLATION

#### 3.1 Unpacking

Carefully unpack all items of the KW2000E and inspect for any damage which may have occurred during transit. Examine all packing materials before discarding to ensure that no parts are inadvertently thrown away. Check all valves and crystals for obvious damage and ensure that they are firmly seated in their respective sockets.

#### 3.2 Fixed Station Installation

Connect the transceiver, power supply, and antenna as shown in fig. 7-3. Connect the transceiver to a good earth ground, such as a metal water pipe, or a metal stake driven deep into moist soil. Connect microphone or key as shown in fig. 7-3. Allow adequate ventilation for the equipment.

#### 3.3 Installation with the KW1000 Linear Amplifier

Connect the transceiver, power supply, KW1000 and antenna as shown in fig. 7-5. Use screened lead for connection between pins 2 and 3 of the OCTAL plug on the KW2000E and the plug marked MOX on the KW1000.

#### 3.4 Mobile Installation

##### 1. Vehicle Installation

Connect the transceiver, power supply, antenna and microphone as shown in fig. 7-4. The most practical installation is to place the transceiver under the instrument panel of the vehicle, with the DC power supply Unit located under the bonnet. A shallow U shaped bracket is available for mobile installation and intended to be bolted upside-down beneath the instrument panel. The transceiver is then slung from the downward projecting arms of the U bracket.

##### 2. Mobile Electrical Installation Procedure

(a) Check that the polarity of the DC power supply is the same as the vehicle.

(b) The cable available for connection between the DC power supply and transceiver is six feet long. This should be remembered when installing in other than a normal passenger vehicle.

(c) A fuse block containing a 25A fuse is available, and should be installed as close to the battery as possible. Install the fuse block in the LIVE side of the battery.

LEAVE THE FUSE OUT UNTIL THE INSTALLATION IS COMPLETE

(d) Use cable capable of carrying 30A, such as 110/0076 for connecting the power supply to the battery. Ensure that no chafing to cables can occur while the vehicle is moving.

#### 3.5 Mobile Antenna Installation

1. One of the most efficient antennas for use on the Amateur bands is the centre-loaded whip. These antennas use an insulated bumper or body mount, with provision for coaxial feed from the base.

2. The centre-loaded whip must be tuned to obtain optimum operation on the desired frequency of operation. They will operate at maximum efficiency over a range of perhaps, 10 KHz on the 160 metre band, 20 KHz on 80 metres, a somewhat wider range on 40 metres, and the whole of 20 metres, without retuning.
3. One procedure for tuning the antenna is as follows. The antenna is installed, and the vehicle parked in an open space, with all doors closed. The end of the coaxial cable which will plug into the transceiver is terminated in a link of 3 to 4 turns of wire. This link is then coupled to a grid-dip meter and the resonant frequency of the antenna determined by noting the frequency at which the G.D.O. dips. The coils furnished with the antenna are normally too large, and on some antennas it may be necessary to remove turns from the loading coil, and others, to vary the length of the top section, to obtain resonance.

### 3.6 Noise Suppression

1. A motor vehicle generates a considerable amount of electrical noise and permit satisfactory reception by a mobile installation it is necessary to reduce this noise to a low level.
2. The ignition system is responsible for a considerable amount of the electrical noise. The sparking plugs should be of the type with built-in suppression, or plug suppressors should be used. It is beneficial to use sheathed cable for the leads from the distributor to the sparking plugs and from the ignition coil to the rotor terminal on the distributor, the sheathing being securely bonded to the car frame. There are two terminals on the ignition coil, the one marked 'SW' should be by-passed to the car frame through 0.1 0.5 uf capacitor.
3. Dynamo whine can be identified by the following procedure. Run the engine at a fast idling speed. Tune the transceiver to a frequency where there are no signals. Switch the ignition off. If the noise persists for a short time after the ignition has been switched off, then it is due to the dynamo. This type of noise can often be eliminated by connecting a capacitance of about 0.5 uf from the 'D' terminal on the dynamo to the car frame. In no circumstances should the field terminal 'F' be by-passed or the regulator action will be impaired and the unit damaged.

### 3.7 Initial checks

Put the HIGH LOW power switch to the required position. Set the MIC GAIN control full counterclockwise. FUNCTION switch to LSB, WAVE-CHANGE switch 3.5, PRE-SELECTOR LF segment. CONTROL switch INT MOX, allow transceiver 60 secs. to warm up. Adjust RVI located on rear of AC PSU, and adjustable through the rubber grommet on the side of the DC PSU, for a standing cathode current of 50mA. Switch to EXT MOX and OFF.

#### CAUTION

DO NOT SET STANDING CATHODE CURRENT TOO LOW;  
AMPLIFIER LINEARITY WILL BE DEGRADED.

DO NOT SET TOO HIGH; PA PLATE DISSIPATION WILL BE  
EXCEEDED AND VALVES DAMAGED.

## SECTION 4

### OPERATION

#### 4.1 Receiver

1. After making external connections as in section 3-2, 3-3 and 3-4 and doing initial checks, as in section 3-7, set controls to the following positions:

AF GAIN	VERTICAL
RF GAIN	FULLY CLOCKWISE
PA TUNE	REQUIRED BAND
PRE-SELECTOR	REQUIRED BAND
CONTROL SWITCH	EXT MOX
IRT TUNE	0
IRT SWITCH	OFF
FUNCTION SWITCH	REQUIRED SIDEBAND
MIC GAIN	FULLY COUNTERCLOCKWISE
PA LOAD	8
WAVE CHANGE SWITCH	REQUIRED BAND

#### 2. Calibration

- (a) Set VFO dial to 0, 100, 200, 300, 400 or 500 with tuning knob.
- (b) Adjust PRE-SELECTOR for maximum signal or noise output.
- (c) Press CAL ON button.
- (d) Tune back and forth near 100 KHz point, until calibrate signal is at ZERO BEAT. Adjust CAL SET until dial is calibrated. Release CAL ON button.

#### 3. Single-Sideband Tuning

- (a) Tune in signal and adjust PRE-SELECTOR for maximum S METER reading, adjust AF GAIN for described audio output level.
- (b) When listening to strong signals, a reduction in background noise under no-modulation conditions may be obtained by rotating RF GAIN control counterclockwise, away from the maximum position.
- (c) To read frequency, add the dial setting to the WAVECHANGE switch setting. For example, if the WAVECHANGE switch is set to 3.5 and the dial is set at 108, the frequency is 3.608 MHz. If the WAVECHANGE switch is set at 14.0 and the dial to 070, the frequency is 14.070 MHz.

#### 4. AM Tuning

Set controls as outlined in 4-1 1. Tune in signal for ZERO BEAT, adjust PRE-SELECTOR for peak S meter reading, and adjust AF GAIN for desired audio output level. Once the desired signal is tuned in, switching to the opposite sideband may yield a more readable signal if interference is present.

#### 5. IRT

If it is desired to tune the receiver off the transmitting frequency, turn the IRT switch to IRT and adjust IRT TUNE, this will vary the frequency by approximately  $\pm 6$  KHz on receive only.

#### 6. IRTT

If it is desired the receiver and transmitter sections may be tuned off the indicated dial frequency. Turn the IRT switch to IRTT, and adjust IRT TUNE, this will vary the frequency by approximately  $\pm 6$  KHz on receive and transmit.

## 7. Use of S Meter

(a) The S Meter is intended to indicate relative rather than absolute signal strength. A nominal meter reading of S-9 is obtained with an input signal of 25 microvolts. Due to normal tolerance in receiver operation, AVC threshold varies slightly from band to band causing correspondingly slight changes in the number of db represented by each S unit, a figure of 4 db per S unit can be taken as correct for all practical purposes.

(b) Due to valve ageing and/or input voltage variations, the S meter may move off the ZERO point with no signal input; to correct, remove the antenna, short the antenna socket to earth, and adjust the potentiometer RV6 until the S meter reads ZERO. Caution, do NOT adjust SENS potentiometer, this has been set at the factory.

## 4.2 Transmitter

Set the transceiver up as in 4-1 1.

### 1. Vox Anti-Vox and Delay

(a) To adjust the VOX circuit, adjust AF GAIN for desired audio output level, put the CONTROL switch to VOX, leave the MIC GAIN control fully counterclockwise.

(b) Speak into the microphone and slowly advance the VOX SENS potentiometer until the relays drop in.

(c) If noise from the loudspeaker tends to trip the VOX relays, advance the ANTI-VOX potentiometer until the effect is stopped.

(d) To adjust the VOX DELAY, that is the time taken for relays to be de-energised, turn the DELAY potentiometer clockwise to increase the delay, and anti-clockwise to decrease the delay.

### 2. Single-sideband Tune Procedure

(a) Set the CONTROL switch to either the VOX or EXT MOX.

(b) With the transceiver set up on the required band, adjust the PRE-SELECTOR in the required band segment, for a peak in noise or peak S meter reading. (Standing I will be ZERO).

(c) Turn the FUNCTION switch to TUNE, this will cause the relays to close, the transceiver will go on to transmit and the TONE oscillators will be switched on, a 1500 KHz note will be heard in the loudspeaker.

(d) Slowly advance the MIC GAIN, this will cause the meter to rise from zero, advance MIC GAIN until cathode current of 50mA is indicated on meter, adjust PRE-SELECTOR for a peak in cathode current, continue to advance MIC GAIN until with the PA TUNE control off RESONANCE, PA cathode current of 130mA flows.

(e) Adjust PA TUNE control for a DIP in cathode current, increase loading of PA by turning PA LOAD control counterclockwise, re-adjust PA TUNE for DIP in cathode current, continue adjustments until PA is loaded to 120mA.

(f) Turn MIC GAIN control fully counterclockwise.

(g) Turn FUNCTION switch to required sideband, it is normal practice to operate on LSB on 160-80 and 40m and USB on 10-15 and 10m.

3. (a) To put the transceiver in the TRANSMIT SSB mode either press the press to talk button on the microphone, operate the external send/receive switch wired to pins 1 and 7 of the octal plug, both with the CONTROL switch at EXT MOX, or turn the CONTROL switch to INT MOX or VOX.

### Single-Sideband Operation

- (b) Note that when the transceiver is in the transmit position the standing cathode current is 50mA.  
(c) Advance the MIC GAIN control while speaking into the microphone until PA cathode current averages 100mA.

#### 4. CW Operation

- (a) Load the transceiver as for SSB TUNE PROCEDURE 4-2 2.  
(b) Unplug the microphone.  
(c) Switch to transmit by operating the external SEND/RECEIVE switch with the CONTROL switch at EXT MOX or putting the CONTROL switch to INT MOX or VOX. With the CONTROL switch at VOX pressing the key will cause the transmitter to operate break-in CW.  
(d) With the transceiver at transmit, press the key and advance the MIC GAIN control until cathode current of 200mA flows, this will give a PA input of 150 watts, do not hold the key down for more than one second, otherwise damage to the PA valves may be done.

#### 5. ITT

If required the transmitter may be tuned off the receiver frequency by approximately  $\pm 6$  KHz. Turn the IRT switch to ITT, and adjust IRT TUNE potentiometer the required amount.

#### 6. 160 Meter SSB Operation

In order to comply with the GPO regulations, a HIGH LOW power switch is fitted to the power supply, and one PA valve is switched out of circuit when on 160 metres.

- (a) Put the HIGH LOW power switch to LOW power.  
(b) Carry out the TUNE PROCEDURE in 4-2 2 (a) to (c).  
(c) Advance the MIC GAIN control for PA OFF RESONANCE cathode current of 90mA.  
(d) Load the PA to 70mA.  
(e) On speech average 50mA cathode current and do not peak above 65mA.

#### 4.3 Setting of PA Load Control

BAND	52 Ohm PA Load Setting
160	8
80	8
40	6
20	5
15	4
10	3 $\frac{1}{2}$

#### 4.4 WWV

Set the WAVE-CHANGE switch to 14.0 MHz and the CONTROL switch to WWV. The Receiver will now tune from 15.0 - 15.5 MHz. Tuning to 15.0 MHz and peaking the PRE-SELECTOR should result in one of the 15.0 MHz frequency standard transmissions being heard. Alignment of the CRYSTAL CALIBRATOR against one of these transmissions is detailed in Section 5.22.

## SECTION 5

### SERVICE INSTRUCTIONS

#### DANGER

EXTREME CARE MUST BE TAKEN WHEN SERVICING THIS EQUIPMENT ESPECIALLY IF ANY COVERS ARE REMOVED SINCE POTENTIALS AS HIGH AS 900 VOLTS ARE PRESENT.

#### 5.1 General

This section covers maintenance and service of the KW2000E SSB Transceiver. It includes information on trouble analysis, signal tracing procedures, voltage and resistance measurements, and alignment procedures. The usefulness of signal level and alignment data given depends upon the accuracy of the test equipment used. Minor adjustments in alignment may be made using the crystal calibrator as a signals source. Except for an occasional touch-up to compensate for possible component ageing, alignment normally will be necessary only if frequency determining components have been replaced. If servicing requires that the cabinet be removed, proceed as follows:

1. Disconnect all power and external connections.
2. Remove the two rear feet and the two front feet from the bottom of the cabinet.
3. From the rear, push the transceiver chassis forward until the front panel protrudes from the cabinet about an inch.
4. Grasping the front panel at the edges, slide the transceiver out of the cabinet.

#### NOTE

Valve filaments and pilot lamps are connected in a series parallel arrangement for 12v operation. When making valve or lamp replacements be sure that rated filament currents are the same as the original units.

#### 5.2 Trouble Analysis

1. Most cases of trouble can be traced to defective valves. Many valve checkers cannot duplicate the conditions under which the valves work in the transceiver. Substitution of new valves will sometimes clear an obscure case of valve trouble. Intermittent trouble conditions in valves can usually be discovered by lightly tapping the envelope. Occasionally valve pins or socket terminals will become dirty or corroded causing an intermittent condition. When this situation is suspected, remove the valve and apply a few drops of contact cleaner to the valve pins. Replace the valve and work it up and down in the socket a few times. Shorted valves or capacitors will often cause associated resistors to overheat and crack, blister or discolour. Making the measurements listed in Table 6-3 will help to isolate this type of trouble to a particular stage or component. A logical process of elimination in conjunction with a study of the main schematic diagram and block diagram will aid in isolating trouble. For example:

##### Receiver

2. If the receiver S METER functions properly, and there is no audio output, then the fault will either be in the CARRIER OSCILLATOR (V2), PRODUCT DETECTOR (V12) or the AF AMP OUTPUT VALVES (V11).

3. If no signal is received and all valves and voltages appear to be correct, the HF CRYSTAL OSCILLATOR (V10) and the VFO (V19) CARRIER OSCILLATOR (V2) may be suspected. These may be tested by checking the operation of the transmitter section, since these oscillators are common to both transmitter and receiver sections of the KW2000E.

#### Transmitter

4. No RF signal passes through the transmitter section until the operator speaks into the microphone, presses the key or puts the FUNCTION switch to TUNE. This means that with no input signal, all stages except the CARRIER OSCILLATOR, the VFO and the HF CRYSTAL OSCILLATOR are quiescent.
5. Should no output be obtained from the transmitter section when the FUNCTION switch is at TUNE or when speaking into the microphone with the FUNCTION switch at LSB or USB and the CONTROL switch at INT MOX, then the fault can be isolated to the stages before or after the BALANCED MODULATOR. By shorting one side of the primary of IFT 1 to chassis, the BALANCED MODULATOR will be unbalanced. If under this condition RF output is obtained the fault must be in the stages before the balanced modulator.
6. If by unbalancing the BALANCED MODULATOR, output is obtained, then the fault can be still further isolated, by putting the FUNCTION switch to TUNE, this should cause a 1400 Hz tone to be heard in the loudspeaker, this indicates that the TONE OSC (V1) is working. If RF output is obtained in the TUNE position, and there is no output on LSB or USB with speech, then either the MIC AMP (V1) or the microphone is at fault; also check microphone plug.
7. In carrying out the above checks, the transceiver should be set up as in the operation instructions.

### 5.3 Signal Tracing Procedures

Tables 6-1, 6-2 list significant test points, normal signal test points and normal signal levels. Figs. 7-1, 7-2 show location of adjustments. Voltages given in the tables are nominal and may vary plus or minus 20 per cent. A signal generator with an accurately calibrated output attenuator must be used to provide the RF signal source indicated. Be careful each time to set signal generator to frequency shown in table. Oscillator output voltages must be measured with a valve voltmeter and RF probe.

1. For audio measurements, use an audio oscillator as the signal source and an a-c VVM or audio wattmeter to monitor receiver output. Set AF GAIN at maximum, and terminate the 3 ohm AUDIO output with a three ohm resistive load.
2. Oscillator injection voltages are measured with VVM with an RF probe.
3. To check RF signal levels, connect DC VVM to the Receiver AGC line. Set RF GAIN fully clockwise. Static DC voltage on the AGC line should be approximately 0.4 volt. Connect the RF signal generator to the point indicated in the table, and vary the generator dial to produce maximum AGC voltage, and compare with the value listed in the table.

### 5.4 Voltage and Resistance Measurements

Tables 6-3, 4 list voltage measurements with the Transceiver on receive and transmit. Table 6-5 lists resistance measurements. Voltages and resistances given in the tables are nominal and may vary plus or minus 20 per cent.

### Alignment Procedure Equipment Required

Complete alignment of the KW2000E requires the use of the following equipment:

- a) SIGNAL GENERATOR (S.G) covering 455 KHz to 30 MHz with output impedance of 52 ohms, type used AIRMEC 201A.
- b) AUDIO OSCILLATOR.
- c) AUDIO WATTMETER.
- d) VALVE VOLTMETER (VTVM) with RF PROBE, type used AIRMEC 314.
- e) 100w 52 ohm DUMMY LOAD OR WATTMETER type used KW107 Supermatch.
- f) Non metallic hexagonal trimming tool, screwdriver.

### 5.5 Alignment Procedure

Before attempting to align the KW2000E please read the instructions very carefully.

1. Set the transceiver up as follows:

AF GAIN	NORMAL LISTENING LEVEL
RF GAIN	FULLY CLOCKWISE (F.C.)
PA TUNE	80m
PRE-SELECTOR	80m L.F. END OF ARROW ON FRONT PANEL
CONTROL SWITCH	EXT MOX
IRT TUNE	0
IRT SWITCH	OFF
FUNCTION SWITCH	LSB
MIC GAIN	FULLY COUNTERCLOCKWISE (F.C.C.)
PA LOAD	F.C.
WAVECHANGE SWITCH	3.5
VFO	000

2. Plug the Signal Generator into the co-axial socket on the rear drop of the transceiver, allow 10 minutes for warm up.

3. Carrier Oscillator Output Level

Check the output of the carrier oscillator with the VTVM and RF probe. See fig. 7-2 for test point "A". A voltage of 1.5v should be obtained on both sidebands.

4. VFO Output Level

Check the output of the VFO with the VTVM and RF probe. See fig. 7-2 for test point "B". A voltage of 0.4v RF should be obtained. If a lower level is obtained this will be due to a faulty ECF82 V19.

5. HF Oscillator Level

Connect the VTVM with RF probe to the point where the 60pf output capacitor joins the adjacent tag strip. See fig. 7-3 for test point "C". Adjust capacitors and inductances for equal reading on band segments as follows. See Fig. 7-2 for location of adjustments. If VTVM is not available connect multimeter to pin 8 of V16 1st RX MIXER (ECC85).

BAND	XTAL FREQUENCY	VTVM READING	AVO READING	L
1.8	4955	1.4v RF	4.0v DC	L1
3.5	6655	2.3v RF	4.2v DC	L2
7.0	10155	1.6v RF	4.1v DC	L3
14.0	2x8577.5	2.7v RF	4.5v DC	L4
WWV	2x9077.5	0.7v RF	3.9v DC	See Below
21.0	2x12077.5	3.2v RF	5.2v DC	L5
28.0	2x15577.5	1.7v RF	4.2v DC	See Below
28.5	2x15827.5	1.9v RF	4.2v DC	L6
29.0	2x16077.5	1.6v RF	4.0v DC	See Below
29.5	2x16327.5	1.6v RF	4.0v DC	L7

On the 15.0, 28.0 and 29.0 MHz ranges the output is tuned by the coil of the adjacent segment. Any de-tuning occurring on the 28.0 and 29.0 MHz ranges is compensated for by a small link coil wired between the 28.5/29.0 MHz switch contacts, a similar coil is wired between the 29.5/29.0 MHz switch contacts. Adjustment of these coils should not be necessary.

#### 5.6 Pre-Selector 3.5 MHz Band

1. Connect the VTVM reading DC NEGATIVE to the AGC line. See fig. 7-2 for test point "D". With no signal input a voltage of 0.4v will be obtained.
2. Set the PRE-SELECTOR pointer so that it is level with the tip of the arrow at LF end of PRE-SELECTOR travel, set VFO to 000.
3. Adjust the output of the S.G. so that there is an input to the transceiver of 25 microvolts at 3500 KHz, rock the S.G. dial until the signal is heard and peak reading on the VTVM is obtained. NOTE: To obtain a 25uv input to the KW2000E the open circuit voltages of the S.G. will be 50uv.
4. Adjust cores of L9 and L23 (see fig. 7-2 for location) for peak VTVM reading.
5. Set VFO dial to 200 and re-tune S.G. to 3.7 MHz, peak PRE-SELECTOR capacitor for maximum AGC voltage.
6. Adjust cores of L9 and L23 for peak VTVM reading.
7. Unplug S.G. and plug in dummy load into transceiver, switch to INT MOX.
8. Adjust the PA bias pot, on the PSU for a standing cathode current of 50mA.
9. Turn control switch to EXT MOX and the function switch to TUNE.
10. Advance MIC GAIN control until cathode current starts to rise and adjust the core of L16 for a peak in cathode current, back off MIC GAIN to keep cathode current below 75mA as L16 is adjusted.

#### 5.7 V.I.F. Transformers and 455 KHz IF

1. Set the transmitter up on 4.0 MHz (wavechange switch 3.5, VFO 500).
2. Switch to TUNE, advance MIC GAIN and adjust the PRE-SELECTOR for a peak in cathode current.

### 5.7 V.I.F. Transformers and 455 KHz IF (Cont'd.)

3. Adjust the core of IFT2 and the core of IFT3 for a peak in cathode current, backing off the MIC GAIN to keep cathode current below 130mA.
4. Change frequency to 3.5 MHz, adjust the concentric trimmers wired across the V.I.F. transformers for a peak in cathode current.
5. Continue to adjust the cores of IFT2/IFT3 at 4.0 MHz and the concentric trimmers at 3.5 MHz, until the drive is flat within  $\pm 3$ db over the band.
6. Unplug dummy load, plug in S.G.
7. Set receiver up on 3.5 MHz and tune S.G. to the same frequency, set to give an input of 25uv.
8. Adjust the cores of IFT4/IFT5 for maximum AGC voltage.

### 5.8 S-Meter Calibration

1. Tune slightly off the 3.5 MHz signal so that it cannot be heard.
2. Note reading on VTVM connected to the AGC test point, it should be in the order of 0.3 to 0.5v.
3. Tune back to 3.5 MHz for maximum AGC voltage and reduce S.G. output to give an input of 1.5uv into the transceiver.
4. Adjust AGC THRESHOLD pot RV5 so that this 1.5uv signal causes the AGC voltage to rise by 0.1v.
5. Tune slightly off the 3.5 MHz signal so that it cannot be heard.
6. Adjust the S-METER ZERO pot RV6 so that the s-meter reads zero.
7. Tune back to 3.5 MHz for max AGC voltage. Increase the RF input to the transceiver to 2.5mV. Adjust the S-METER LINEARITY pot RV11 so that the s-meter reads S9 +40db.
8. Check s-meter zero, if adjustment is required re-check the 40db point.  
When the s-meter is calibrated as above a 25uv signal should read approx. S9.
9. Unplug S.G. plug in dummy load.

### 5.9 Carrier Balance

1. Connect VTVM reading RF direct across dummy load.
2. Load transceiver to 120mA. A reading of 35v RF should be obtained on VTVM with MIC gain advanced. Switch to INT MOX and USB.
3. Turn MIC gain FCC adjust RV2 and C12 for minimum reading on VTVM. It should be possible to balance down to 0.2v on both side bands.
4. Turn function switch back to USB, control switch to EXT MOX.

### 5.10 Transmitter Sensitivity

1. Turn MIC GAIN FCC. Function switch to INT MOX.
2. Plug the audio generator into the MIC SOCKET f 1.7 KHz output ZERO, and switched to 600 ohm Load.
3. Turn the MIC GAIN control FC.
4. Increase the output of the audio generator until the cathode current reaches 120mA.

### 5.10 Transmitter Sensitivity (Cont'd.)

5. Input required for stated cathode current should be less than 1mV.
6. Turn control switch to EXT MOX. MIC GAIN FCC.
7. Unplug audio generator.
8. Unplug dummy load and plug S.G. into transceiver.

### 5.11 VFO Calibration and IRT

1. With IRT switch at IRT and IRT tune at 0, tune the transceiver to 4000 KHz using the 100 KHz calibrator as the signal source. Check the accuracy of the 100 KHz signal against a known accurate 100 KHz signal, zero beat by adjusting C158. Check the CAL SET knob pointer is VERTICAL.
2. (a) Check the tracking of the VFO at each 100 KHz point. If it is overtracking at 3.5 MHz reduce the capacity of C80 by inserting a probe through the hole in the top of the VFO and turning the Philips trimmer anticlockwise.  
(b) Reset the VFO dial at 4.0 MHz and adjust the core of L29 (see fig. 7-3) for zero beat. Repeat the above adjustments until the tracking is correct.  
(c) If the VFO is undertracking, increase the capacity of C80 by turning the Philips trimmer clockwise. Re-adjust at 4.0 MHz for zero beat. Repeat until the tracking is correct.
3. Tune to zero beat at 3700 KHz and turn the IRT switch to OFF, adjust RV3 (IRT set pot) for zero beat. See fig 7-3 for location.
4. ULSB Switching  
(a) Switch to LSB, adjust L29 LINK <sup>on 29.5 MHz VFO dial</sup> ~~by inserting a probe through the lower hole in the VFO box~~ for ZERO BEAT, (when transceiver is switched to LSB, RL3 closes completing the circuit of L29 link to earth, causing the frequency of the VFO to increase by an amount equal to the spacing of the carrier crystals, approximately 3 KHz).  
(b) Switch back to USB and check that ZERO BEAT is still maintained, repeat (a) until switching between USB and LSB ZERO BEAT is maintained.  
(c) Leave function switch on USB.

### 5.12 Pre-Selector 29.5 MHz Band

1. Connect the VTVM to the AGC test point, set VFO dial to 500.
2. Set the PRE-SELECTOR pointer so that it is level with the tip of the arrow at HF end of PRE-SELECTOR travel.
3. Tune the S.G. to 29.5 MHz, set to give an input of 25uv. Rock S.G. dial until a signal is heard.
4. Adjust cores of L14 and L27 for a maximum VTVM reading, final adjustments should give 4v AGC for 25uv input. Unplug S.G., plug in dummy load.
5. Turn function switch to TUNE, advance MIC GAIN for increase in cathode current, adjust L21 for peak in cathode current.

### 5.13 Neutralising 29.5 MHz Band

1. Load the transmitter up to 120mA as in Section 4-2.
2. Check that MAXIMUM RF output occurs when PA cathode current is at DIP, i.e. move PA TUNE capacitor either side of DIP and note that RF output drops, if it does not, note which side of dip output increases, if it

### 5.13 Neutralising 29.5 MHz Band (Cont'd.)

2. is on the LF side then reduce value of C56 neutralising capacitor, if it is on the HF side, increase value of C56 repeat until maximum output occurs when PA is at dip. Re-adjust L21 for peak in cathode current.
3. It is only necessary to neutralise on the 29.5 MHz band, as all other bands have fixed value neutralising capacitors, switch to USB. Unplug dummy load, plug in S.G.

### 5.14 Pre-Selector 29.0 MHz Band

No adjustments are necessary on this band, as the 29.5 MHz band coils are used, and are tuned to the lower frequency with the Pre-selector capacitor.

### 5.15 Pre-Selector 28.5 MHz Band

1. Leave VFO and PRE-SELECTOR capacitor in same position as for 29.5 MHz.
2. Tune S.G. to 28.5 MHz set to give an input of 25uv. Rock S.G. dial until a signal is heard.
3. Adjust cores of L13 and L27 for maximum AGC voltage. Unplug S.G., plug in dummy load.
4. Turn function switch to TUNE, advance MIC GAIN and peak cathode current by adjustment of L20. Turn MIC GAIN F.C.C.
5. Turn function switch to USB. Unplug dummy load, plug in S.G.

### 5.16 Pre-Selector 28.0 MHz Band

No adjustments are necessary on this band, as the 28.5 MHz band coils are used.

### 5.17 Pre-Selector 21.0 MHz Band

1. Leave VFO and PRE-SELECTOR capacitor in same position as for 28.5 MHz.
2. Tune S.G. to 21.5 MHz, set to give an input of 25uv. Rock S.G. dial until signal is heard.
3. Adjust cores of L12 and L26 for maximum AGC voltage. Unplug S.G., plug in dummy load.
4. Turn function switch to TUNE, advance MIC GAIN and peak cathode current by adjustment of L19. Turn MIC GAIN F.C.C.
5. Turn function switch to USB. Unplug dummy load, plug in S.G.

### 5.18 Pre-Selector Receiver 15.0 MHz Band

1. Turn control switch to WWV with wavechange switch set to 14.0 MHz band.
2. Set VFO dial to 000, leave PRE-SELECTOR capacitor in same position as for 21.5 MHz.
3. Tune S.G. to 15.0 MHz, set to give an input of 25uv. Rock S.G. dial until a signal is heard.
4. Adjust cores of L11 and L25 for maximum AGC voltage.
5. Return control switch to EXT MOX position.

NOTE: The Transmitter is rendered inoperative when WWV is selected.

#### 5.19 Pre-Selector 14.0 MHz Band

1. Set VFO dial to 000.
2. Tune S.G. to 14.0 MHz, set to give an input of 25uv. Rock S.G. dial until signal is heard.
3. Peak signal by means of the PRE-SELECTOR capacitor note where this peak occurs. Leaving the capacitor in this position adjust L11 and L25 for maximum AGC voltage. Unplug S.G., plug in dummy load.
4. Turn function switch to TUNE, advance MIC GAIN and adjust L18 for peak in cathode current. Turn MIC GAIN F.C.C.
5. Turn function switch to USB. Unplug dummy load, plug in S.G.

#### 5.20 Pre-Selector 7.0 MHz Band

1. Set VFO dial to 000. Set the PRE-SELECTOR pointer so that it is level with the tip of the arrow at LF end of PRE-SELECTOR travel.
2. Tune the S.G. to 7.0 MHz, set to give an input of 25uv. Rock S.G. dial until signal is heard.
3. Adjust cores of L10 and L24 for maximum AGC voltage.
4. Set VFO dial to 100 and re-tune S.G. to 7.1 MHz. Rock S.G. dial until signal is heard.
5. Adjust PRE-SELECTOR capacitor for maximum AGC voltage.
6. Peak cores of L10 and L24 for maximum AGC voltage. Unplug S.G., plug in dummy load.
7. Turn function switch to TUNE, advance MIC GAIN and peak cathode current by adjustment of L17. Turn MIC GAIN F.C.C.
8. Turn function switch to USB. Unplug dummy load, plug in S.G.

#### 5.21 Pre-Selector 1.8 MHz Band

1. Set VFO dial to 000. Set the PRE-SELECTOR pointer so that it is level with the tip of the arrow at LF end of PRE-SELECTOR travel.
2. Tune S.G. to 1.8 MHz, set to give an input of 25uv. Rock S.G. dial until signal is heard.
3. Adjust cores of L8 and L22 for maximum AGC voltage.
4. Set VFO dial to 100 and re-tune S.G. to 1.9 MHz. Rock S.G. dial until signal is heard.
5. Adjust PRE-SELECTOR capacitor for maximum AGC voltage.
6. Adjust cores of L8 and L22 for maximum AGC voltage. Unplug S.G., plug in dummy load.
7. Turn function switch to TUNE, advance MIC GAIN and peak cathode current by adjustment of L15. Turn MIC GAIN F.C.C.
8. Turn function switch to USB.

#### 5.22 Alignment of the 100 KHz Calibrator using 15.0 MHz Frequency Standard

Set the Receiver up on one of the 15.0 MHz frequency standard transmissions as detailed in section 4-4. Tune the signal until it is just zero beat, switch on 100 KHz calibrator. If the 15.0 MHz harmonic of the 100 KHz crystal is also zero beat no adjustment is required. If it is not adjust the calibrator trimmer C158 until a zero beat is obtained.

TABLE 6-1

## SIGNAL LEVELS RECEIVER 3.5 MHz BAND

TEST SIGNAL INJECTION POINT	GENERATOR OUTPUT FREQUENCY	GENERATOR OUTPUT VOLTAGE	NORMAL INDICATION
Pin 3 V11 AF Amp	1700 Hz	6.5 V	1.5w AF o/p
Pin 1 V11 AF Amp	1700 Hz	110mV	1.5w AF o/p
Pin 3 V12 Product Det	Carrier Osc injection	-	1.6-2.6v RF
Pin 1 V13 2nd IF Amp	455 KHz	100mV	3.0v AGC
Pin 1 V14 1st IF Amp	455 KHz	600uV	3.0v AGC
Pin 1 V15 2nd RX Mixer	V.F.O. injection	-	0.3-0.5v RF
Pin 5 V15 2nd Rx Mixer	455 KHz	1.8mV	3.0v AGC
Pin 7 V15 2nd Rx Mixer	455 KHz	800uV	3.0v AGC
Pin 7 V15 2nd Rx Mixer	3055KHz	1.1mV	3.0v AGC
Pin 8 V16 1st Rx Mixer	HF Osc injection	-	0.7-3.2v RF
Pin 6 V16 1st Rx Mixer	3055KHz	1.0mV	3.0v AGC
Pin 2 V16 1st Rx Mixer	3055KHz	1.0mV	3.0v AGC
Pin 2 V16 1st Rx Mixer	3600KHz	4mV	3.0v AGC
Pin 1 V17 RF Amp	3600KHz	200uV	3.0v AGC
Antenna	3600KHz	25uV	3.0v AGC

Signal Generator termination 52 ohms, injection via 0.01uF capacitor except antenna measurement. Transceiver on 3600 KHz.

TABLE 6-2

SIGNAL LEVELS TRANSMITTER

FREQUENCY	3600 KHz
FUNCTION	TUNE
CONTROL	EXT MOX
MICROPHONE	DISCONNECTED
ANT SOCKET	DUMMY LOAD
PRE-SELECTOR	PEAKED ON 80m

To prevent damage to PA valves while measurements are being taken it is advisable to remove the screen voltage from the PA valves V7/8 pin 2.

Adjust the Mic Gain control for 0.5v RMS on its wiper.

TEST POINT	FREQUENCY	RF/AF VOLTAGE	DC VOLTAGE
Pin 6 V1b Mic Amp	1.4 KHz	22 v	160v
Wiper Mic Gain	1.4 KHz	0.5v	0v
Wiper Carrier Balance Pot*	456.00KHz	300mV	0v
Wiper Carrier Balance Pot	454.60KHz	420mV	0v
Primary IFT 1	454.60KHz	400mV	0v
Secondary IFT 1	454.60KHz	360mV	0v
G Terminal Mech Filter	454.60KHz	9.5v	0v
P Terminal Mech Filter	454.60KHz	4.5v	250v
Pin 2 V4 1st Tx Mixer	454.60KHz	4.5v	0v
Pin 3 V4 1st Tx Mixer*	2599.0KHz	450mV	0v
Pin 1 V4 1st Tx Mixer	3053.6KHz	3.5v	165v
Pin 4 IFT 2	3053.6KHz	3.5v	165v
Pin 4 IFT 3	3053.6KHz	2v	0v
Pin 2 V5 2nd Tx Mixer	3053.6KHz	2v	0v
Pin 3 V5 2nd Tx Mixer*	6655.0KHz	1.8v	4.5v
Pin 1 V5 2nd Tx Mixer	3601.4KHz	12v	230v
Pin 2 V6 Driver	3601.4KHz	12v	0v
Pin 7 V6 Driver	3601.4KHz	105v	245v
Pin 5 V7/8 PA	3601.4KHz	80v	-69v

\* These measurements are taken with the Mic Gain control F.C.C.

TABLE 6-3

## VOLTAGE MEASUREMENTS RECEIVE CONDITION

BAND 3.5  
AF GAIN FCC  
FUNCTION LSB  
CAL ON

MIC  
CONTROL

DISCONNECTED  
EXT MOX

## VALVE PIN CONNECTIONS

V	1	2	3	4	5	6	7	8	9
V1a Mic Amp 12AX7	84	0	0.6	0	12.6a	-	-	-	6.3a
V1b Tone Osc 12AX7	-	-	-	0	12.6a	210	-1.47	0	6.3a
V2a Cath Foll 12AT7	220	-70	0	0	12.6a	-	-	-	6.3a
V2b Carr Osc 12AT7	-	-	-	0	12.6a	100	0	0	6.3a
V3 Tx IF Amp EF183/6EH7	0	-59	0	6.3a	0	0	250	250	0
V4 1st Tx Mix 12AT7	240	-84	0	0	12.6a	240	-84	0	6.3a
V5 2nd Tx Mix 12AT7	230	-84	0	0	12.6a	230	-84	0	6.3a
V6 Driver 6CH6	-	-84	0	12.6a	6.3a	-	240	238	0
V7 Power Amp 6146	0	0	0	0	-69*	0	6.3a	0	820 TC
V8 Power Amp 6146	0	12.6a	0	0	-69*	0	6.3a	0	820 TC
V9 AGC Det 6AL5	0	0	12.6a	6.3a	5.1	-	0	-	-
V10 HF Osc 6AM6	-2.7b	0	6.5	0	225	0	162b	-	-
V11 AF Amp ECL82/6BM8	0	20	0	0	6.3a	235	250	1	100
V12 Prod Det 12AX7	160	0.73	0.75	0	12.6	-	-	-	-
V13 2nd IF Amp 6BA6	0	0	6.3a	0	240	130	1.2c	-	-
V14 1st IF Amp 6BA6	0	0	6.3a	0	220d	130d	7.2d	-	-
V15 2nd Rx Mix 6BE6	0	1	12.6a	6.3a	245	46	0	-	-

TABLE 6-3 (Cont'd.)

VOLTAGE MEASUREMENTS RECEIVE CONDITION (Cont'd)

V	1	2	3	4	5	6	7	8	9
V16 1st Rx Mix ECC85 6F09	245	0	4.4B	6.3a	12.6a	240	0	4.4b	0
V17 RF Amp 12BZ6	0	0.7	12.6a	0	235	130	0	-	-
V18 Xtal Cal 6BA6	-55	0	6.3a	12.6a	R.F. Volts	115	0	-	-
V19 VFO 6U8	125	0	78	0	6.5	72	1.5	5.4	1.25

- a Denotes an AC voltage
- b Voltage varies with band
- c Varies with setting of RV6
- d Varies with setting of RV5
- \* Dependant on PA bias pot setting

TABLE 6-4

VOLTAGE MEASUREMENTS TRANSMIT CONDITION

BAND	3.5	FUNCTION	LSB
MIC GAIN	FCC	MIC	CONNECTED
CAL	OFF	CONTROL	INT MOX

VALVE PIN CONNECTIONS

V	1	2	3	4	5	6	7	8	9
V1a Mic Amp 12AX7	80	0	0.56	0	12.6a	-	-	-	6.3a
V1b Tone Osc 12AX7	-	-	-	0	12.6a	200	-1.45	0	6.3a
V2a Cath Foll 12AT7	190	0	3.2	0	12.6a	-	-	-	6.3a
V2b Carr Osc 12AT7	-	-	-	0	12.6a	100	0	0	6.3a
V3 Tx IF Amp EF183/6EH7	1	0	1	6.3a	0	0	50	62	-
V4 1st Tx Mix 12AT7	170	0	1.85	0	12.6a	170	0	1.92	6.3a
V5 2nd Tx Mix 12AT7	230	0	4.4	0	12.6a	230	0	4.4	6.3a
V6 Driver 6CH6	-	0	3.6	12.6a	6.3a	-	230	210	0
V7 Power Amp 6146	0	0	3.6	12.6a	-69*	0	6.3a	0	800 TC
V8 Power Amp 6146	0	12.6a	245	0	-69*	0	6.3a	0	800 TC
V9 AGC Det 6AL5	-73	0	12.6a	6.3a	4.9	-	-73	-	-
V10 HF Osc 6AM6	-2.7b	0	6.5	0	225	0	150b	-	-
V11 AF Amp ECL82/6BM8	0	20	0	0	6.3a	230	250	1	100
V12 Prod Det 12AX7	200	-62	0	0	12.6	-	-	-	-
V13 2nd IF Amp 6BA6	-59	0	6.3a	0	240	180	0	-	-
V14 1st IF Amp 6BA6	-59	0	6.3a	0	220	126	1.3	-	-

TABLE 6-4 (Cont'd.)

VOLTAGE MEASUREMENTS TRANSMIT CONDITION (Cont'd)

V	1	2	3	4	5	6	7	8	9
V15 2nd Rx Mix 6BE6	-71	0	12.6a	6.3a	245	240	-70	-	-
V16 1st Rx Mix ECC85/6AQ8	245	-60	0	6.3a	12.6a	165	-69	0	0
V17 RF Amp 12BZ6	-66	0	12.6a	0	235	240	0	-	-
V18 Xtal Cal 6BA6	0	0	6.3a	12.6a	250	240	45.5	-	-
V19 VFO 6U8	125	0	78	0	6.5	72	1.5	5.4	1.25

a. Denotes an AC voltage

b. Voltage varies with band

\* Dependant upon PA bias pot setting

TABLE 6-5

RESISTANCE MEASUREMENTS

HT LINE TO EARTH	3.1K OHM	BAND	3.5
EHT LINE TO EARTH	INF	AF GAIN	FC
TX BIAS LINE TO EARTH	150K OHM	RF GAIN	FC
AGC LINE TO EARTH	470K OHM	FUNCTION	OFF
		MIC GAIN	FCC
		CONTROL	EXT MOX
		IRT	OFF
		POWER	DISCONNECTED
		MICROPHONE	DISCONNECTED

VALVE PIN CONNECTIONS

V	VALVE	FUNCTION	1	2	3	4	5	6	7	8	9
V1a	12AX7	Mic Amp	245K	1M	1K	0	0	-	-	-	0
V1b	12AX7	Tone Osc	-	-	-	0	0	125K	150K	3.3K	0
V2a	12AT7	Cath Foll	40K	670K	2.2k	0	0	-	-	-	0
V2b	12AT7	Carr Osc	-	-	-	0	0	25k	100K	3.5	0
V3	EF183	Tx IF Amp	100	1.2M	100	0	0	0	39k	55K	0
V4	12AT7	1st Tx Mix	10K	220K	220	0	0	10K	220K	220	0
V5	12AT7	2nd Tx Mix	4.7K	220K	1K	0	0	4.7K	220K	1K	0
V6	6CH6	Driver	0	150K	100	0	0	0	3.1K	11K	0
V7	6146	Power Amp	0	0	0	0	INF	0	0	0	
V8	6146	Power Amp	0	0	0	0	INF	0	0	0	
V9	6AL5	AGC Det	0	470K	0	0	1K	-	260K	-	-
V10	6AM6	HF Osc	100K	0	0	0	8K	0	54K	-	-
V11	ECL82	AF Amp	1M	470	470K	0	0	3.5K	3.1K	2.2K	245K
V12	12AX7	Prod Det	72K	350K	680	0	0	-	-	-	0
V13	6BA6	2nd IF Amp	940K	0	0	0	4.1K	19K	68 <sup>c</sup>	-	-
V14	6BA6	1st IF Amp	100K	0	0	0	7.8K	19K	80 <sup>d</sup>	-	-
V15	6BE6	2nd Rx Mix	47K	270	0	0	10K	71K	100K	-	-
V16	ECC85	1st Rx Mix	7.8k	470k	1K	0	0	7.8k	100k	1K	0
V17	12BZ6	RF Amp	470K	56	0	0	4.6K	400K	0	-	-
V18	6BA6	Xtal Cal	1M	0	0	0	100k	220K	0	-	-
V19	6U8	VFO	5.8K	68K	48K	0	0	28K	270	680	100K

c Reading dependant upon setting of RV6

d Reading dependant upon setting of RV5

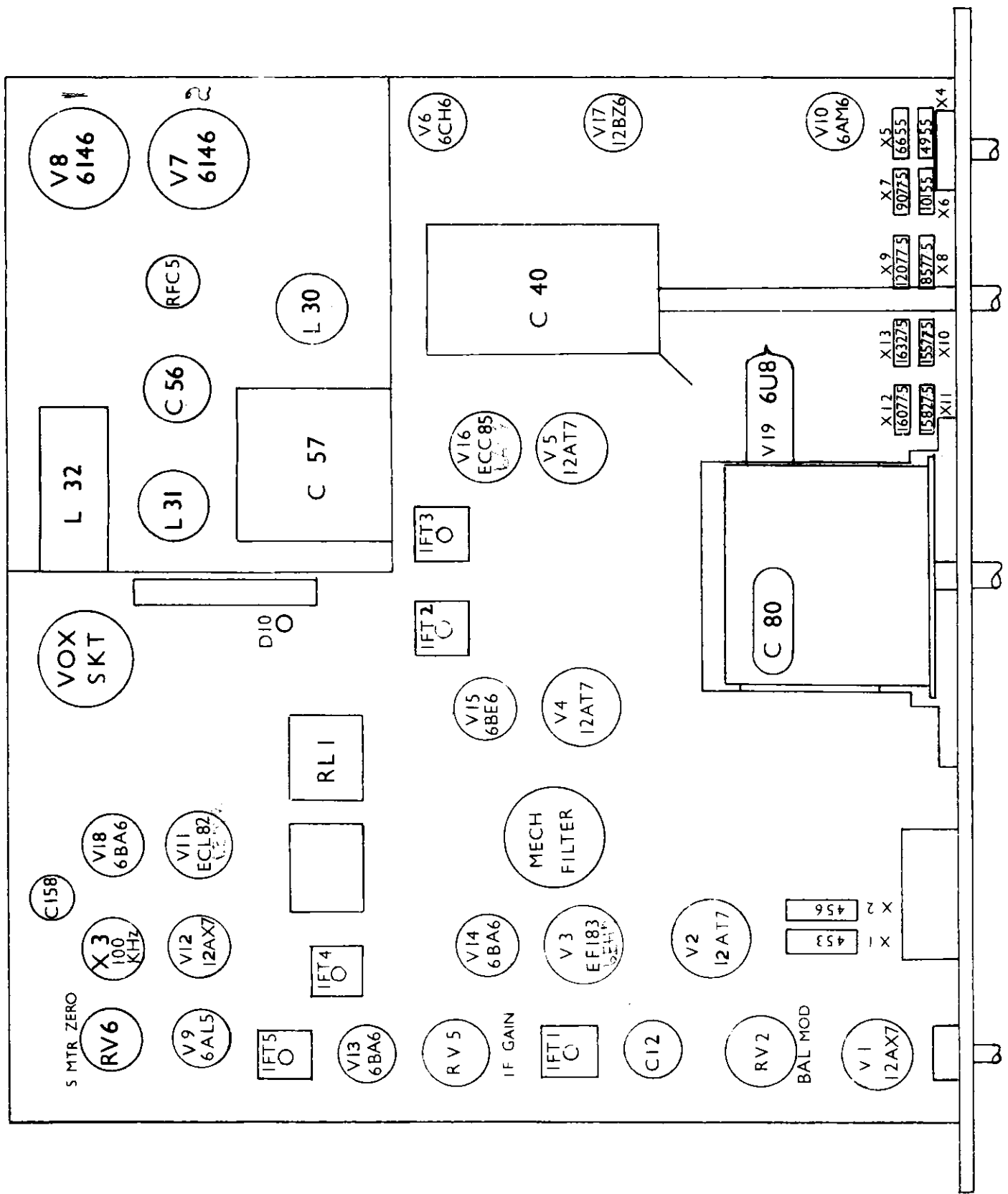

FIG 7-1 LOCATION OF VALVES AND CRYSTALS

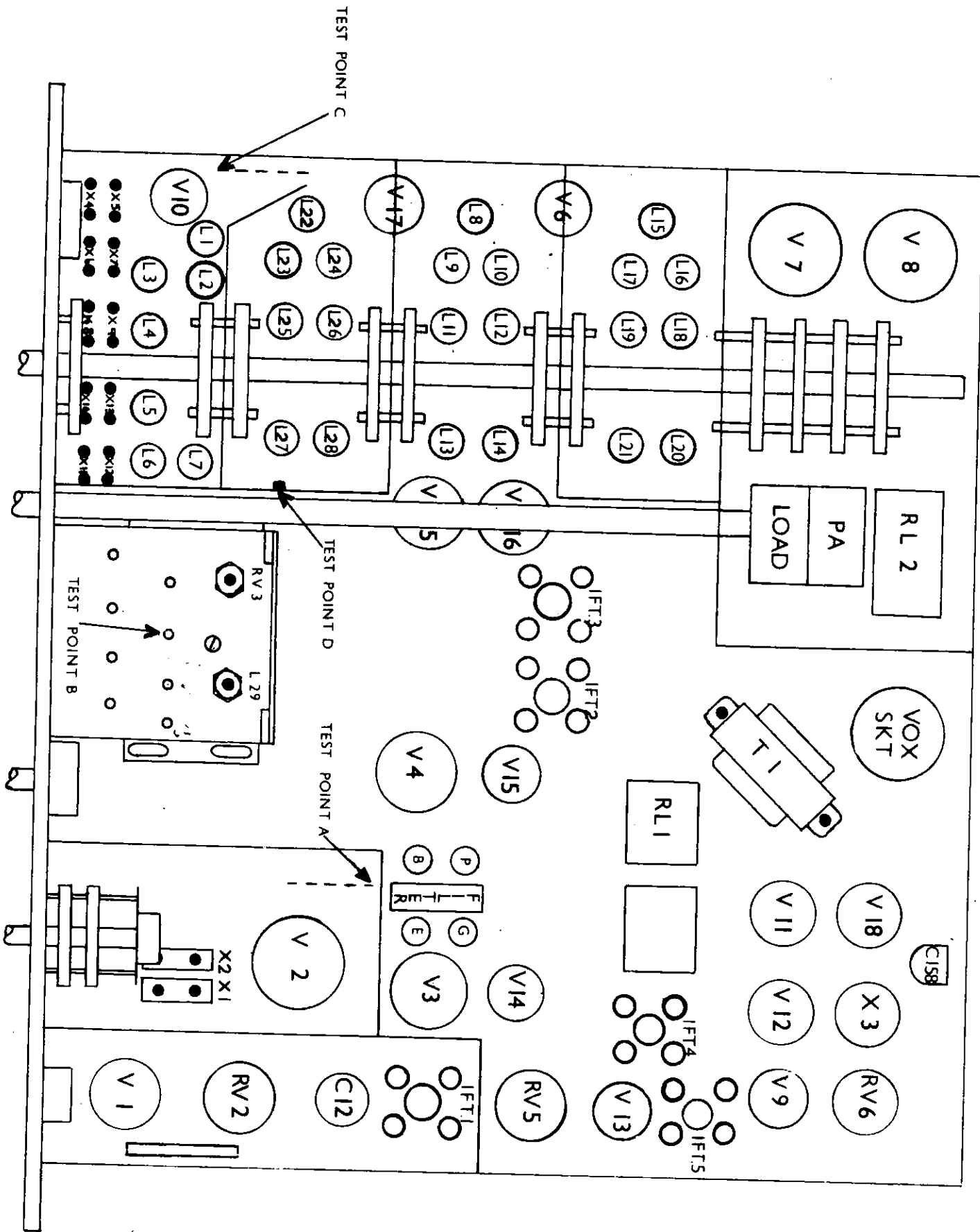
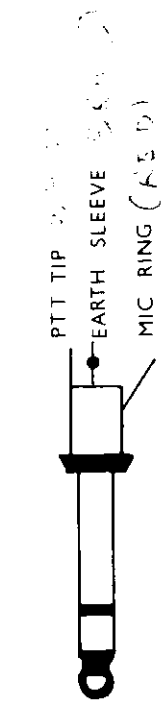
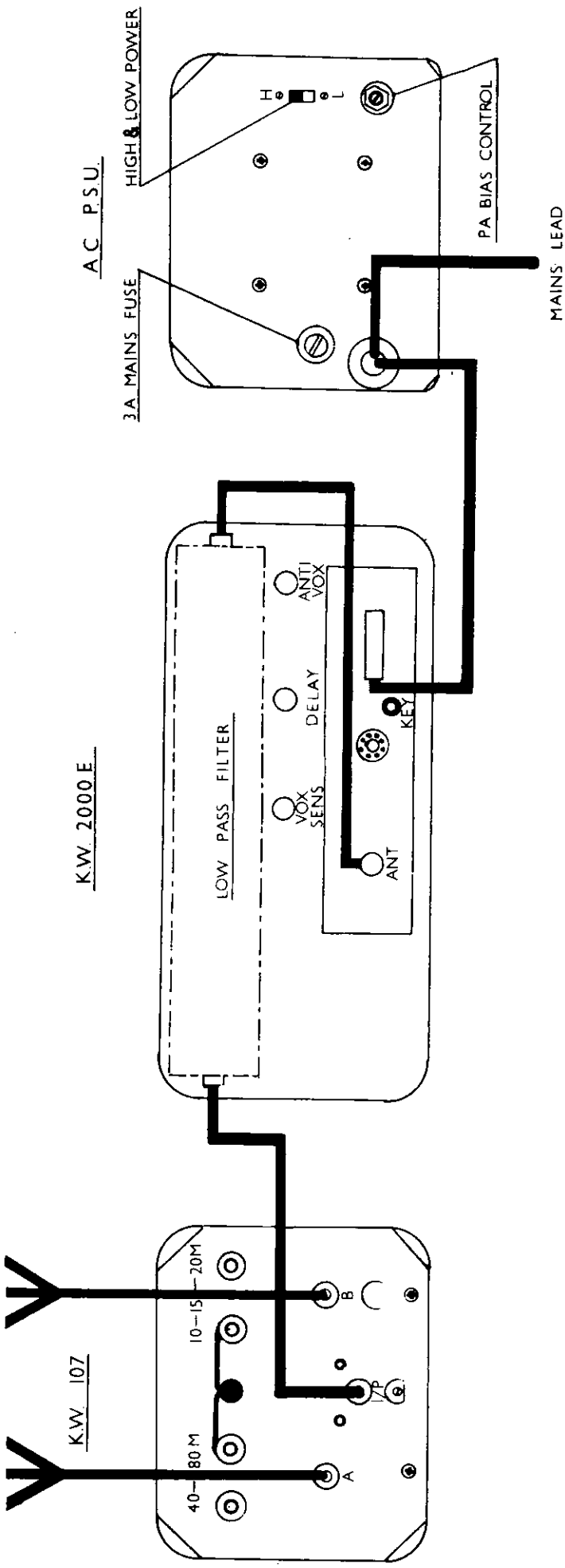

FIG 7-2 LOCATION OF ADJUSTMENTS



MICROPHONE PLUG CONNECTIONS

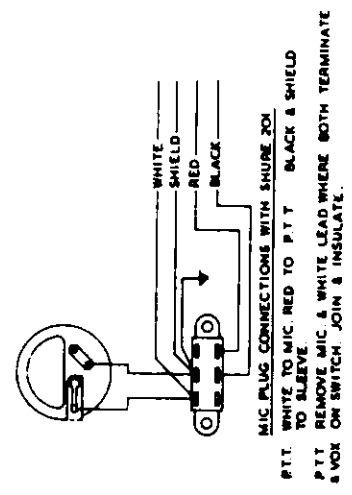

FIG 7-3 INTERCONNECTIONS FIXED STATION

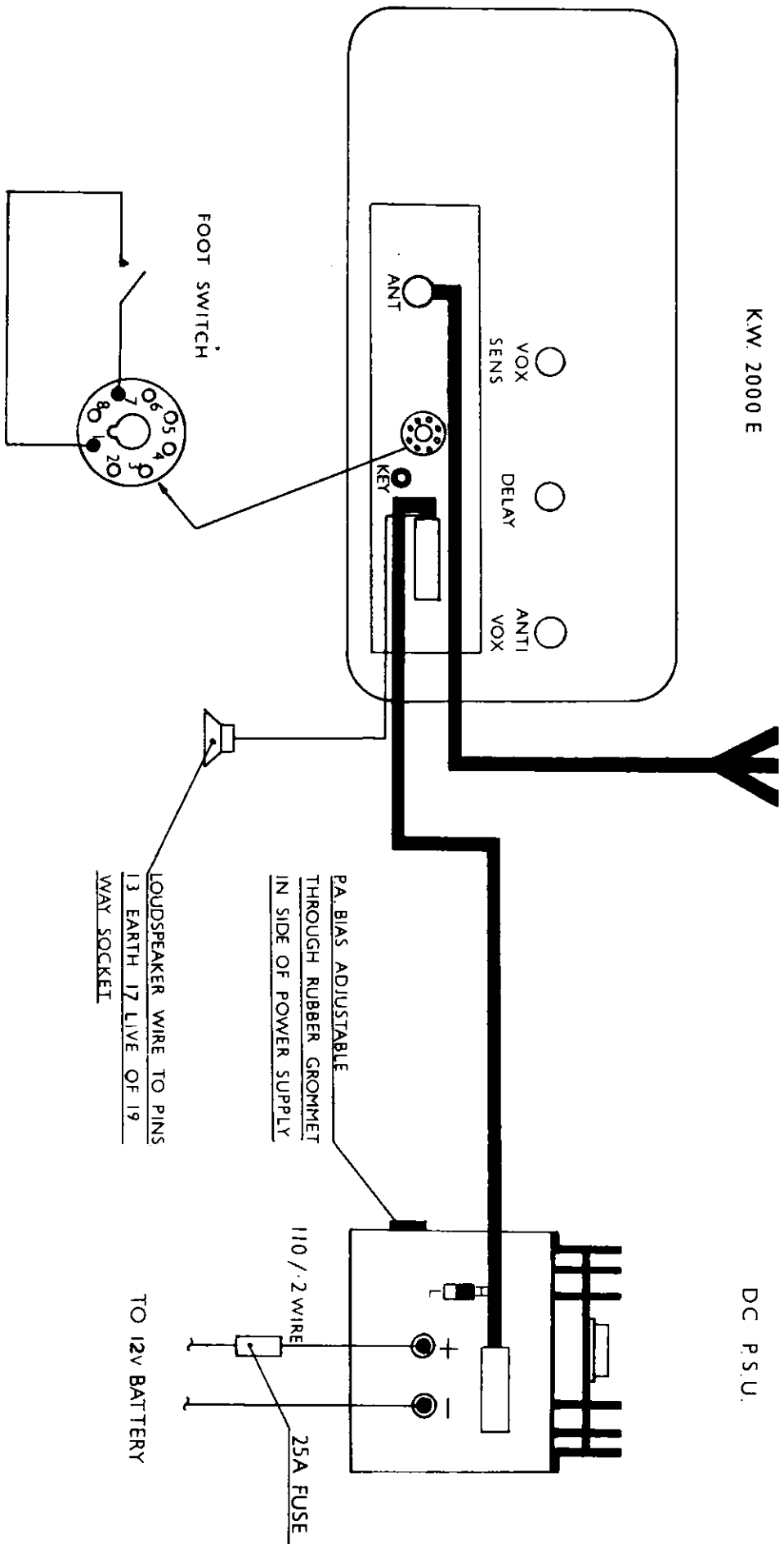

FIG 7-4 INTERCONNECTIONS MOBILE STATION

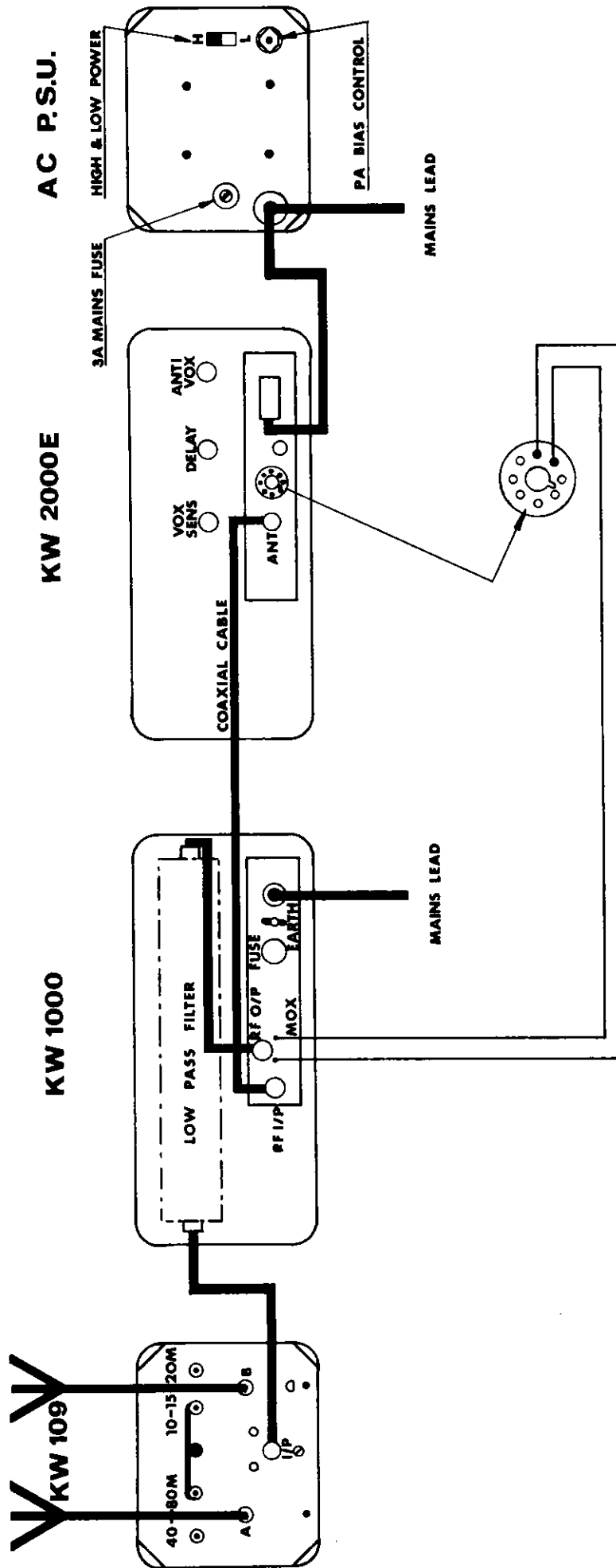

FIG 7-5 INTERCONNECTIONS WITH KW 1000

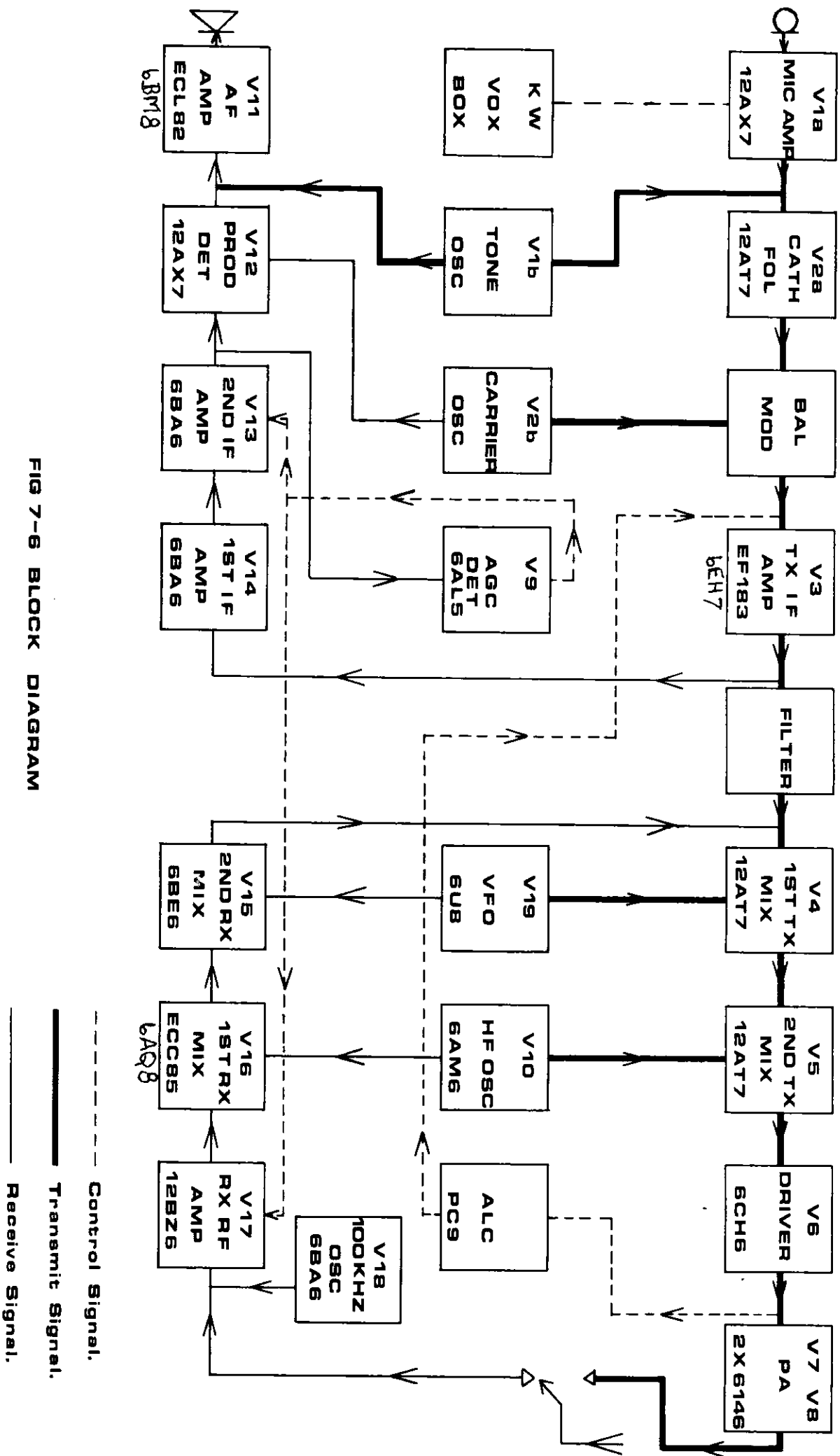
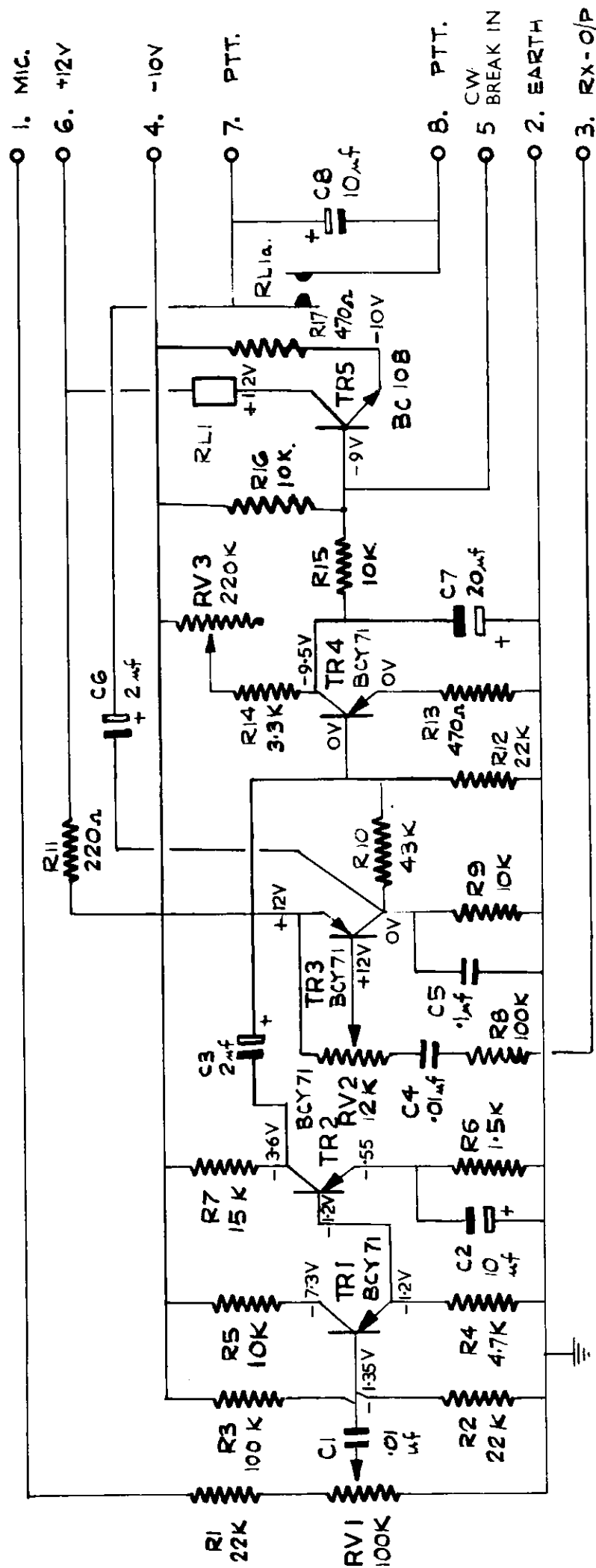

FIG 7-6 BLOCK DIAGRAM

--- Control Signal.  
 — Transmit Signal.  
 - - - Receive Signal.



RV1 VOX GAIN  
 RV2 ANTI TRIP  
 RV3 DELAY

ALL VOLTAGES TAKEN WITH 2000 E SWITCHED TO VOX

**K W VOX UNIT Circuit Diagram**



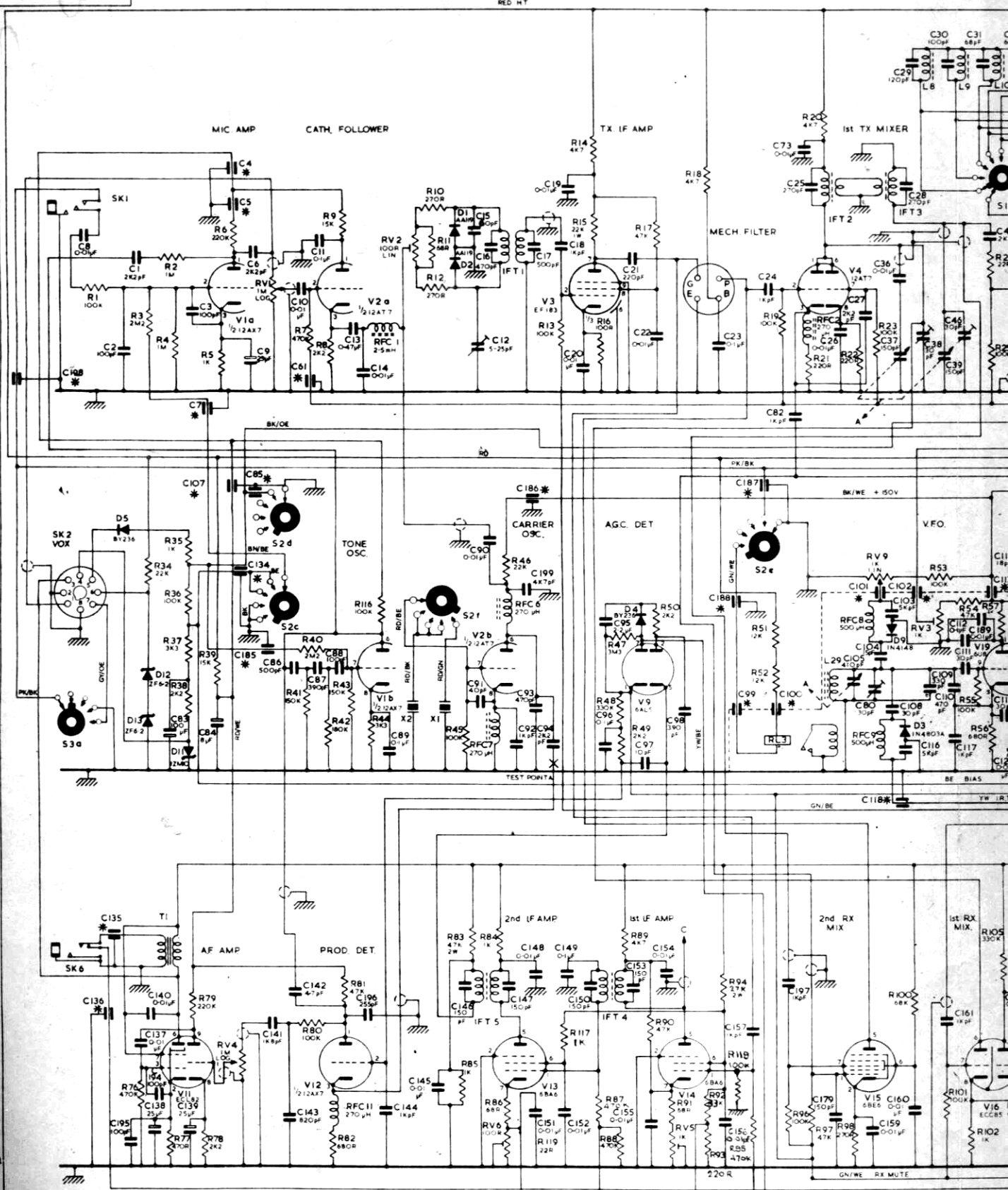

CRYSTALS			POTENTIOMETERS		
CIR. REF.	FREQ.	FUNCTION	CIR. REF.	FUNCTION	
X1	453	LSB XTAL	RV1	MIC. GAIN	
X2	456	USB XTAL	RV2	BAL MOD	
X3	100	CAL. XTAL	RV3	I.R.T. SET	
X4	4955	KHz	RV4	A.F. GAIN	
X5	6655	KHz	RV5	I.F. GAIN	
X6	10155	KHz	RV6	S-METER ZERO	
X7	9077.5	KHz	RV7	R.F. GAIN	
X8	8577.5	KHz	RV8	I.R.T. TUNE	
X9	12077.5	KHz	RV9	CAL. SET	
X10	15577.5	KHz	RV10	TX/RX FREQ	
X11	15277.5	KHz	RV11	S-METER LIN	
X12	18077.5	KHz			
X13	16327.5	KHz			

EXT. SKT.		VOX SKT.		CAPACITORS	
PIN No.	FUNCTION	PIN No.	FUNCTION	CIR. REF.	FUNCTION
1	EARTH	2	AUDIO	C37	I.F.
2	LINEAR SW	3	EARTH	C39	I.F.
3	LINEAR SW	4	ANTI-TRIP	C40a	PA TUNE
4	Q-MULT	5	+12V	C57	I.B.M.H.
5	KEY	6	C.W. BREAK IN	C58	PA LOAD
6	N/C	7	+12V	C40b	PRES. SELECTOR
7	P.T.T.	8	EARTH	C105	VFO
8	Q-MULT			C40c	PRES. SELECTOR

SWITCHES		FUNCTION	
CIR. REF.	SWITCH	CIR. REF.	FUNCTION
S1	POS. SHOWN	S1	WAVECHANGE
S2	OFF	S2	FUNCTION
S3	W.W.V.	S3	W.W.V. EXT. INT. VOX
S4	I.R.T.	S4	I.R.T.
S5	OFF	S5	I.R.T. CAL.

NOTE

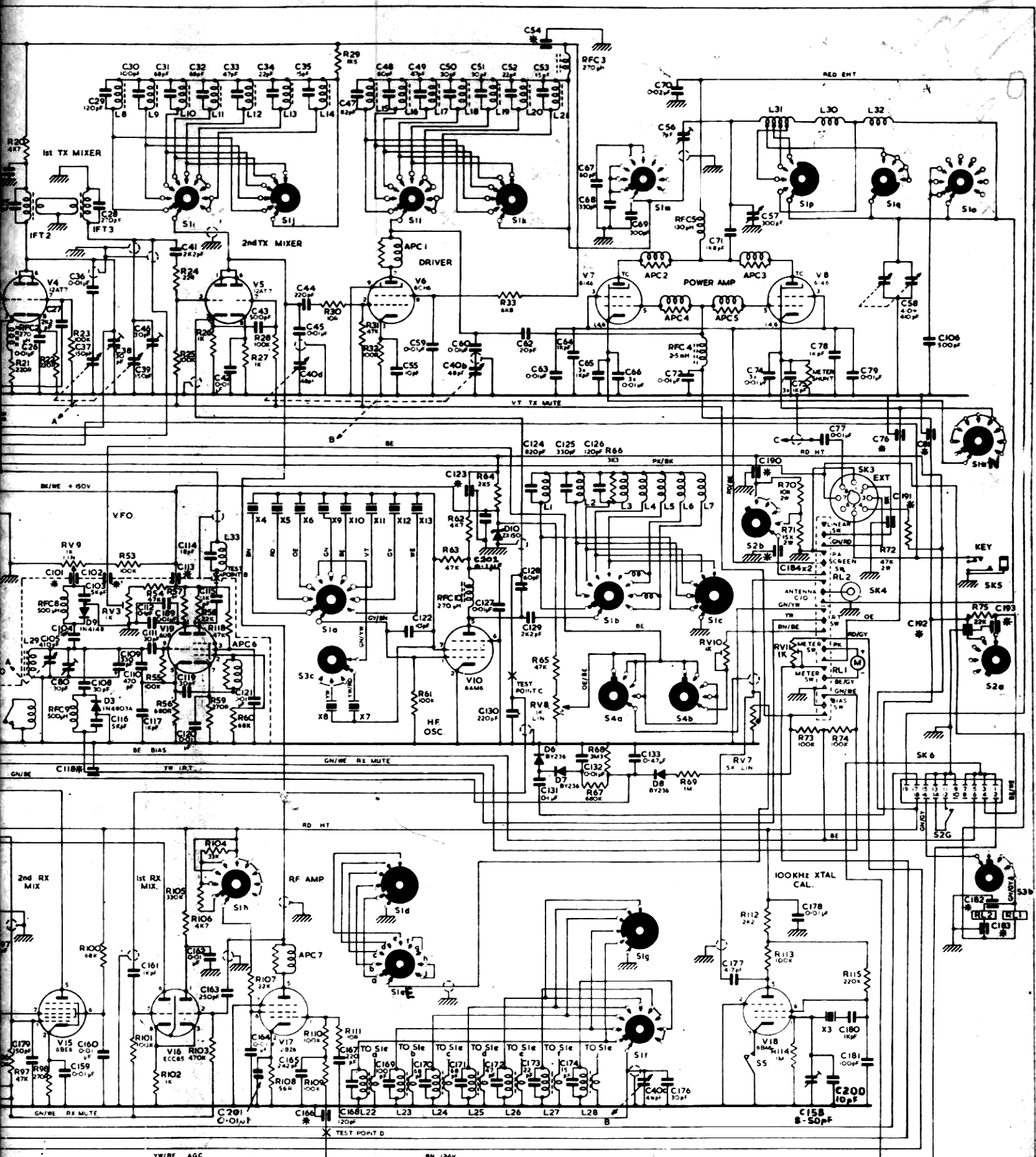

SWITCHES	FUNCTION
SW1	POWER
SW2	WAVECHANCE
SW3	FUNCTION
SW4	WV EXT. INT. VOX
SW5	I.R.T. CAL.

NOTE  
 \* DENOTES 1000pF FEEDTHRO' CAPACITOR.  
 ALL SWITCHES SHOWN IN FULLY ANTI-CLOCKWISE POSITION.

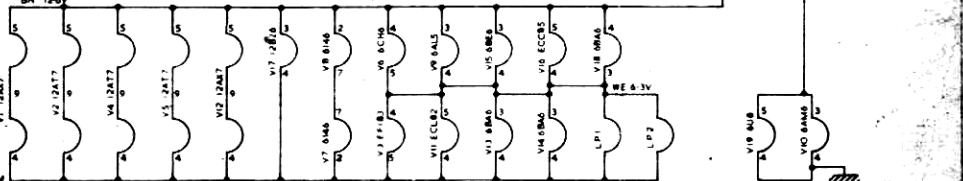

3	5-7-73	NM 38TQ4724/N753	MATERIAL	TOLERANCES	K. W. ELECTRONICS DARTFORD KENT	TITLE KW 2000E CIRCUIT DIAGRAM	DRG. NO. D1033/2
2	18-4-73	AM.SMT.4447/C/N.718	FINISH				
1	11-4-73	ORIGINAL ISSUE	SCALE	DIMENSIONS IN INCHES			
4	7-11-73	AM.SMT.4498/C/N.751	ISSUE	DATE			

### REPAIRS UNDER GUARANTEE

If the material or equipment was purchased direct from K.W. COMMUNICATIONS LTD., and you wish to return it for service under guarantee, you should write to the address shown below giving full particulars including the details listed. Upon receipt of such notice, K.W. will promptly advise you respecting the return. Failure to secure our advice prior to forwarding of the goods or failure to provide full particulars may cause unnecessary delay in handling of your returned merchandise.

#### ADDRESS

K.W. COMMUNICATIONS LTD.,  
SERVICE SECTION,  
VICEROY WORKS,  
R/O 23 HIGH STREET,  
CRAYFORD,  
KENT.

Tel: CRAYFORD 22040

#### INFORMATION NEEDED

- (a) Type number, name and serial number of equipment.
- (b) Date of delivery of equipment.
- (c) Nature of trouble.
- (d) Number of hours of service.
- (e) Cause of trouble if known.

If the equipment was purchased from an Agent it should be returned to the Agent for service.

### OUT OF GUARANTEE REPAIRS

If you wish to return your equipment for repairs, write to the above address giving full particulars including the details listed. Upon receipt of such notice, K.W. will advise you respecting return. Do not send goods without first obtaining our advice.

#### INFORMATION NEEDED

- (1) Type number, name and serial number of equipment.
- (2) Number of hours of service.
- (3) Complete instructions detailing work to be performed.
- (4) Your return address.
- (5) Method of shipment by which the equipment should be returned.
- (6) Special instructions.

### SERVICE QUERIES

Any technical queries regarding K.W. Communications Equipment should be addressed to our Crayford Works and marked "For the attention of Service Section".

K.W. 2000E AC. PSU. CIRCUIT DIAGRAM

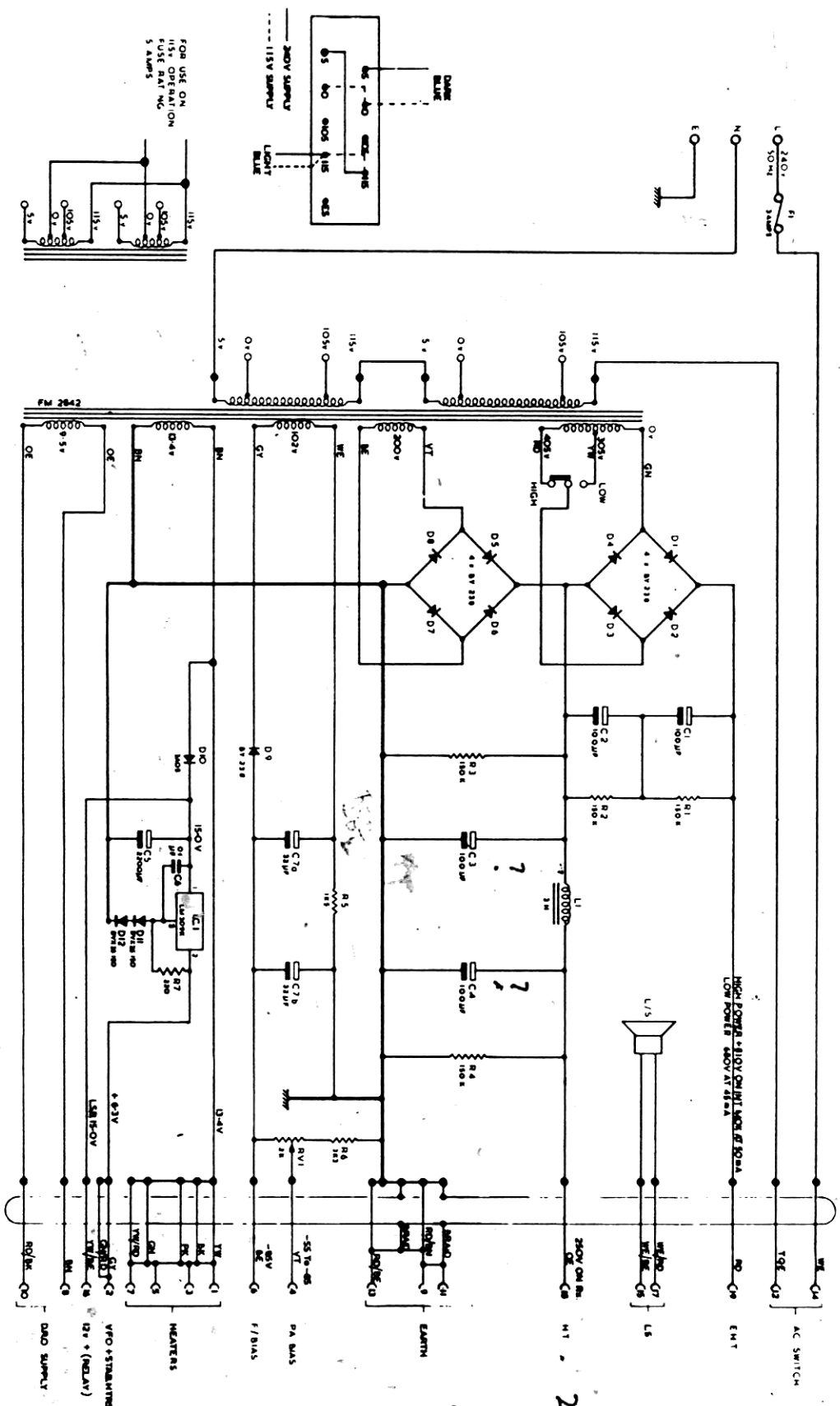

FOR USE ON  
115V OPERATION  
FUSE RAT. NC  
5 AMP-5

*Handwritten notes:*  
 250V  
 heaters ✓  
 if you are  
 worried  
 1/2 meter  
 tube